

**SPECIFICATION**  
**COMMERCIALY AVAILABLE**

**SAW BP FILTER**  
**PART NUMBER: SF100070**

Revised per ECO 4413: Added square corner orientation note.

ISSUED / REVISION	ENGINEER APPROVED	DOCUMENT CHECKED	DRAFTSMAN
1/4/16 XX			
11/23/09 DS			
1/18/11 PM			
5/15/12 kn	<b>06/05/2012 TFG</b>		<b>06/05/2012 GL</b>
<b>10/18/2012 GL</b>	<b>10/18/2012 TFG</b>		<b>10/18/2012 GL</b>

***FILTRONETICS Inc***

1. Part Number: SF100070

2. Electrical Specifications:

Parameter	Unit	Minimum	Typical	Maximum
Center Frequency	MHz	99.80	100.00	100.20
Insertion Loss at F <sub>0</sub>	dB		18.00	19.00
1 dB Bandwidth	MHz	6.20	6.30	
3 dB Bandwidth	MHz	7.00	7.20	
40dB Bandwidth	MHz		10.60	11.00
Passband Variation	dB		0.30	0.50
Group Delay Variation	nsec		30	50
Absolute Delay	usec		1.24	
Ultimate Rejection	dB	55	60	
Substrate Material	-		YZ-LiNbO3	
Ambient Temperature	°C	-40	25	80

3. Mechanical Package and Marking:

Marking:  
Filtro  
SF100070  
WWYY

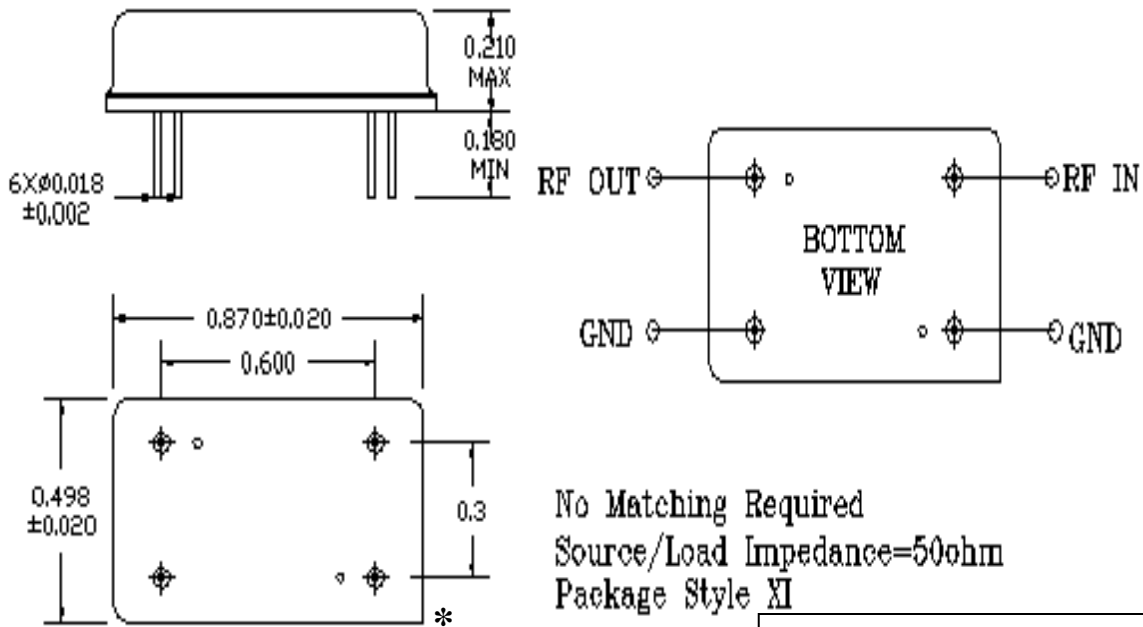

\* Note:  
Square corner denotes orientation.

4. Plots:

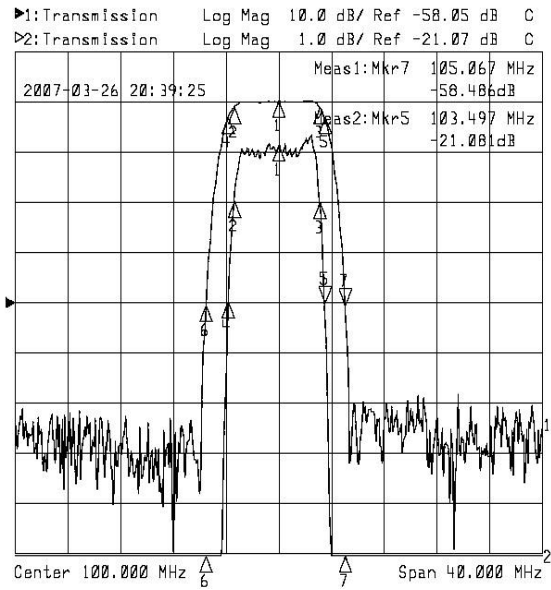

Horizontal: 4MHz/Div

Vertical: 1dB/Div&10dB/Div

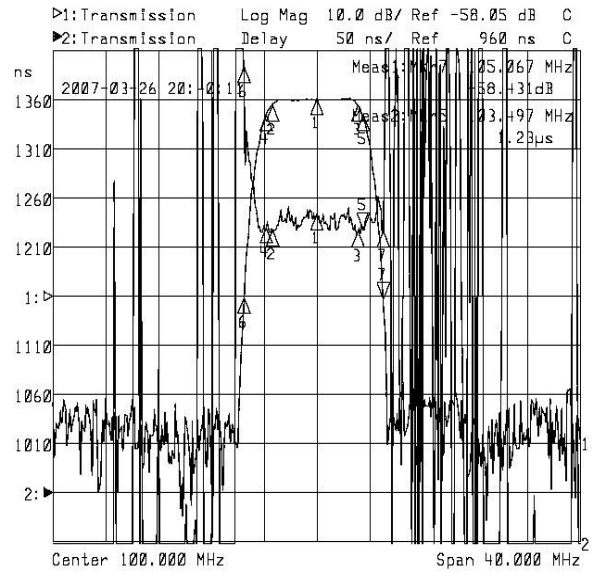

Horizontal: 4MHz/Div

Vertical: 50nsec/Div&10dB/Div