

SPECIFICATION

COMMERCIALLY AVAILABLE

CERAMIC BAND PASS FILTER
PART NUMBER: FNP-1524

ISSUED / REVISION	ENGINEER APPROVED	DOCUMENT CHECKED	DRAFTSMAN
12/24/2020 ^(ASM)			

FILTRONETICS Inc

1. Part Number: FNP-1524

2. Electrical Specifications:

Parameter	Unit	Specification
Center Frequency	MHz	2300
Bandwidth	MHz	$F_c \pm 110$ (2190 ~ 2410MHz)
3dB Bandwidth		320 Min.
Insertion Loss in BW	dB	1.5 Max.
Ripple in BW	dB	1.0 Max.
Return Loss in BW	dB	17 Min.
Attenuation	dBc	50 Min. @ DC ~ 1300MHz
		50 Min. @ 1300 ~ 1600MHz
Input Power	Watt	1.0 Max.
IN/OUT Impedance	Ω	50
Operating Temp. Range	$^{\circ}\text{C}$	-40 ~ +85
Connector	-	SMA (Female) – All ports
Finish	-	White Chromate

3. Mechanical Package Style:

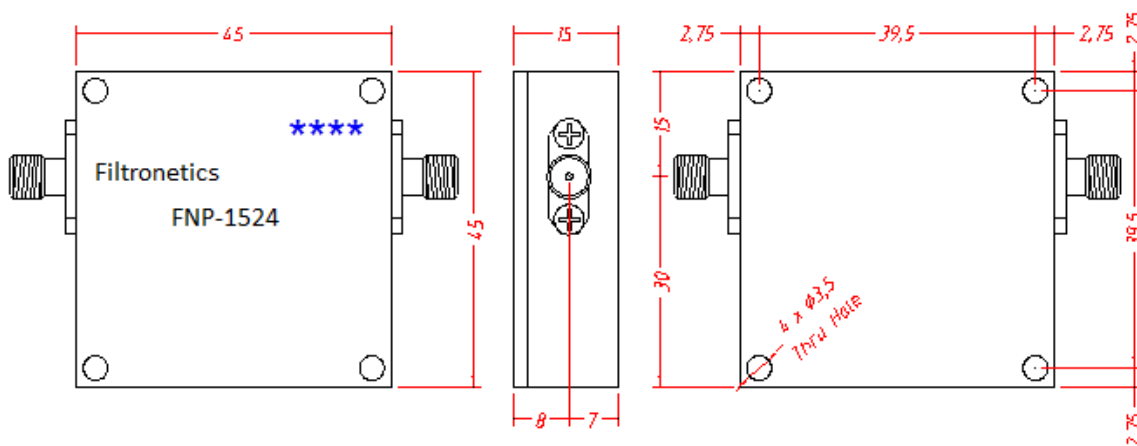

NOTES:

1. Encased package
2. Dimensions in millimeters
3. Tolerance unless specified: ± 0.3
4. **** Date code (YYWW)

4. Response Plot:

9/7/2020 3:43:23 PM
1311.6010K64-101529-xj

Trc1 — S21 dB Mag 10 dB/ Ref 0 dB Cal int Trc3 — S11 dB Mag 5 dB/ Ref 0 dB Cal int
Trc4 — S22 dB Mag 5 dB/ Ref 0 dB Cal int

1

