

SPECIFICATION

COMMERCIALY AVAILABLE

CERAMIC BAND PASS
PART NUMBER: FNP-1021
No Pure Tin

7/20/15 Updated Processing Temp.

ISSUED / REVISION	ENGINEER APPROVED	DOCUMENT CHECKED	DRAFTSMAN
10/2008	03/04/2014 TFG		03/04/2014 GL
7/20/15 TG ^(kn)			

FILTRONETICS Inc

1. Part Number: FNP-1021

2. Electrical Specifications:

NO	ITEMS	Ref.	SPECIFICATION
1	Center Frequency (Fo)	a1	1600 MHz
2	3.0dB Band Width	b1	50 MHz +/-10%
3	Insertion Loss AT Fo	a1	3.2 dB Max
4	V.S.W.R AT Fo+/-20MHz	-	1.75:1 Min
5	Attenuation [absolute value]	At 1550 MHz	20 dB Min
		At 1650 MHz	19 dB Min
6	Group Delay Variation AT Fo+/-20MHz	-	30ns Max
7	Impedance	-	50Ω
8	Maximum Input Power	-	1 W (+30dBm)
9	Operating Temperature Range	-	-40 ~ +85°C
10	Processing Temperature	-	+150°C for 1 hour or +230°C for 10 minutes
		-	6Hr Max @ 100°C / 3 cycles Max with 4Hr cool down between each cycle
11	Workmanship	-	J-STD-001

S21 LOG MAG NETWORK ANALYZER

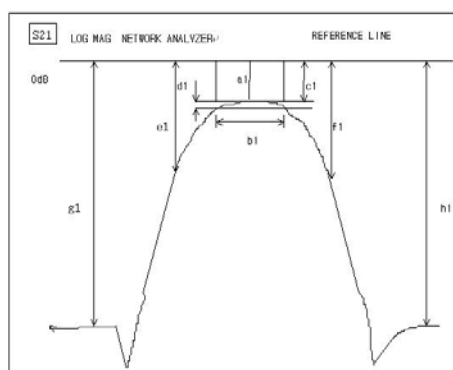

S11 LOG MAG NETWORK ANALYZER

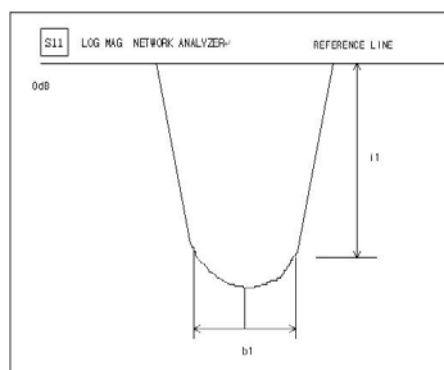

3. Mechanical Package Style:

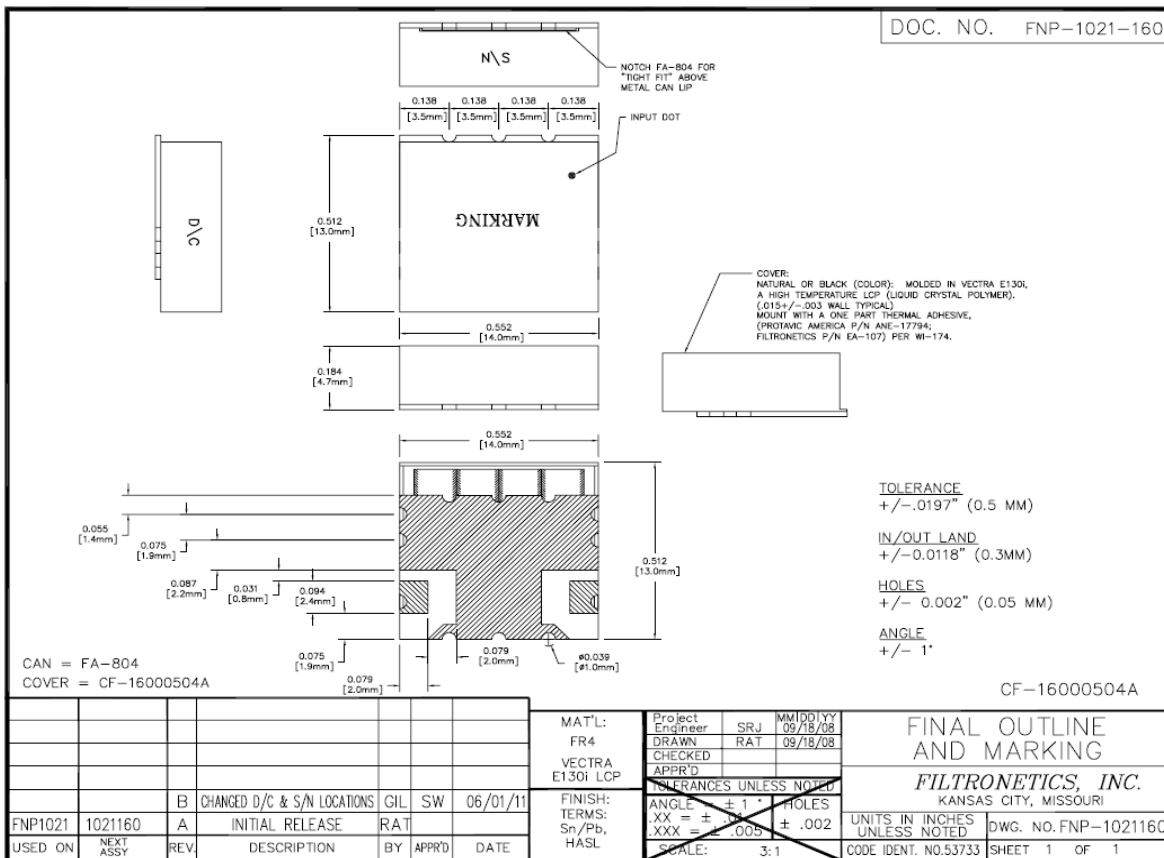

MATERIAL SPECIFICATION

- 1 PCB
 - 1) MATERIAL: FR4
 - 2) TERMINALS: Sn/Pb, HASL
2. METAL CASE
 - 1) Ag or Ni plated brass
3. RESONATOR
 - 1) COATING MATERIAL: silver plate, 8~30um
4. INTERNAL SOLDER
 - 1) Sn96.5/Ag3.5 Lead Free solder, 221 deg C melting
5. RESONATORS TABS
 - 1) Sn/Pb(9:1) Plated or Ag brass
6. NO PURE TIN ALLOWED

MARKING

Label Material: High temp polyimide

Marking:
CF-16000504A
Filtronetics
Date Code

UNIT: MM
 TOLERANCE: +/-0.5MM
 IN/OUT LAND: +/-0.3MM

- **CAUTIONS:**
 1. When handling products, be careful not to damage the outer-electrode.
 2. When handling these products, be careful not to touch the outer-electrode with bare hands or solder-ability is reduced.
 3. Do not apply excessive pressure or shock to product in handling or in transportation or damage to the ceramic filters may result.

4. Graphs

S21 vs. S11 (INSERTION LOSS, RETURN LOSS, V.S.W.R, SMITH CHART)

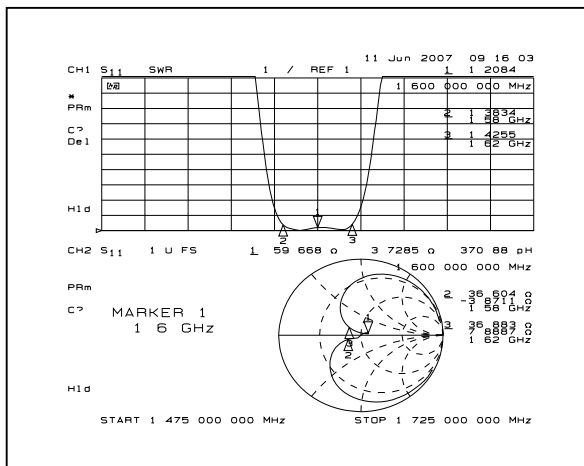
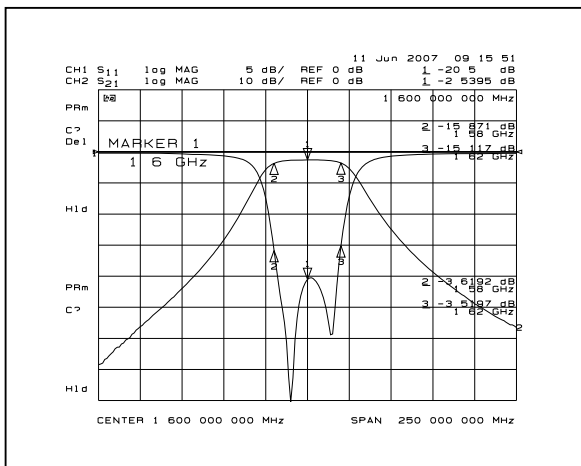

S21 (3dB BAND WIDTH, GROUP DELAY)

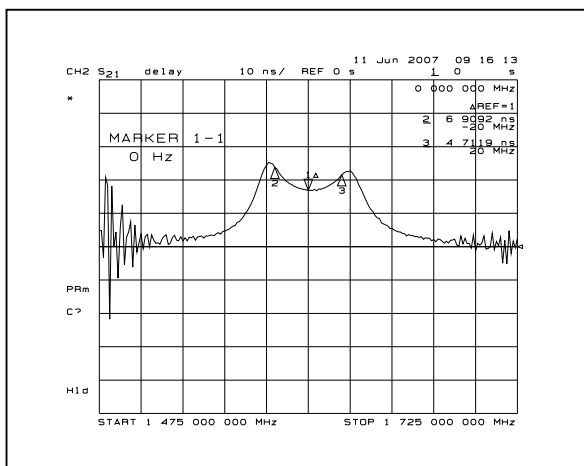
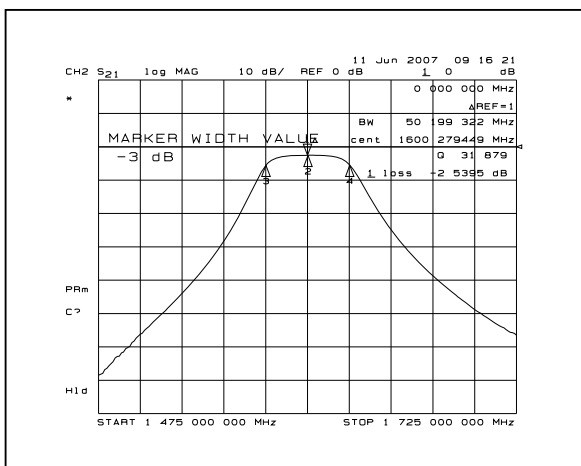

S21 (ATTENUATION, OUT BAND ATTENUATION)

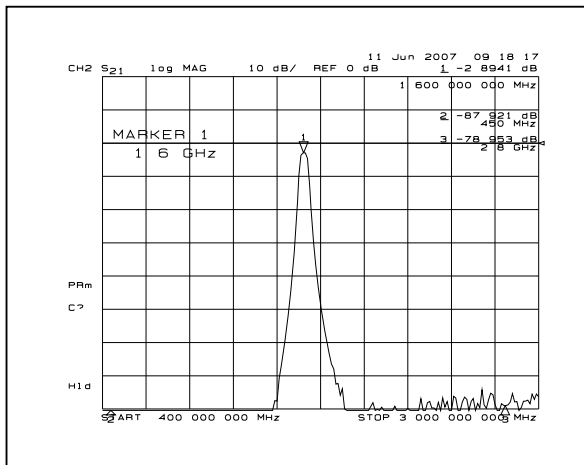
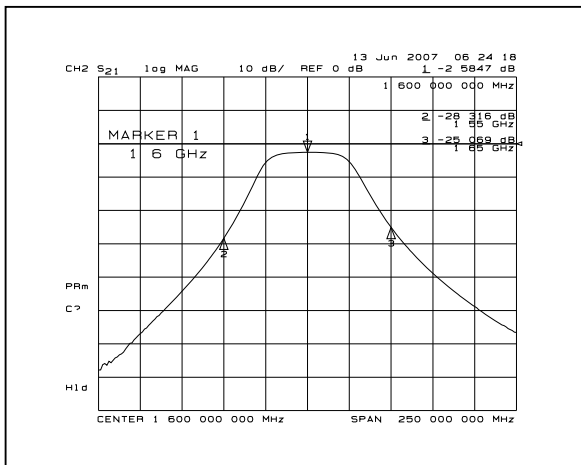

Recommended Solder Pattern:

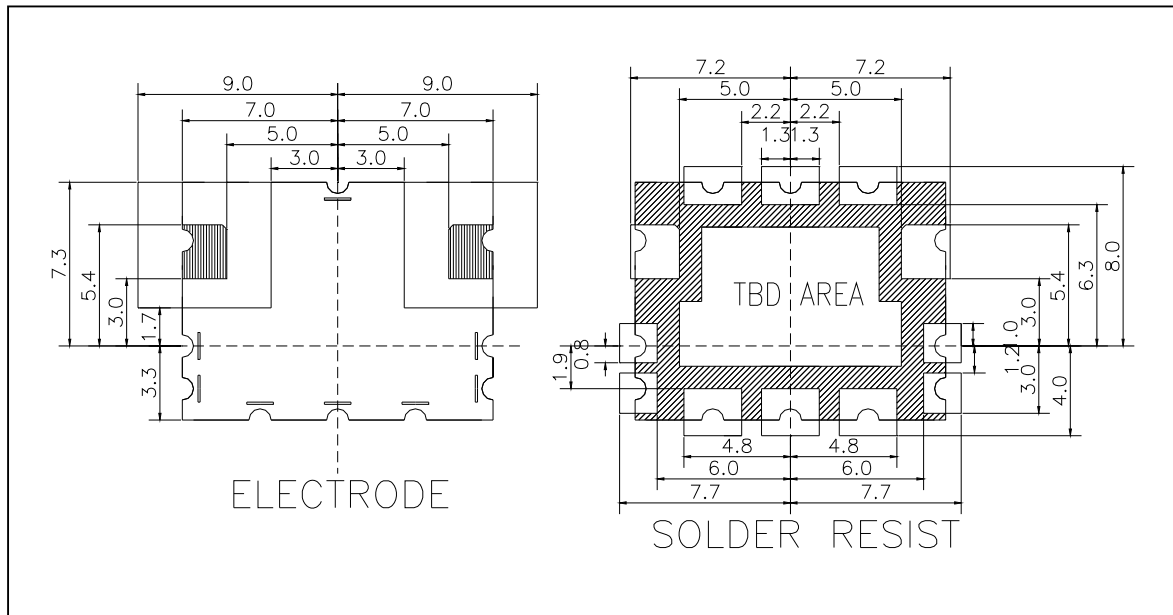

Quality Conformance Test 100% Final inspection	
100% Test Data ***	
1)	Visual mechanical to IPC-610 Class 3. Including inspection for cleanliness.
2)	Thermal Shock -44 to +85°C 10 cycles
3)	Electrical Specifications at ambient

5. DEFINITIONS:

TERMS	DESCRIPTION	SPECIFICATION
Center Frequency	The midpoint of through band pass filter pass band, normally expressed as the arithmetic mean of the -3dB point. Also called Fo.	3. SPECIFICATION
Pass Band Width	The width of the pass band of a filter referenced to the minimum insertion loss point in the pass band. The pass band of a filter is stated as -1.0dB bandwidth.	
Insertion Loss	The loss of the filter, in dB, measured at center frequency relative to a through line (0 dB).	
Attenuation	Reduction of RF power through a filter measured in dB, at desired band and referenced to 0 dB. (Filter to be removed from circuit)	
Pass Band Ripple	Variations in loss in the pass band of the filter, superimposed upon the fundamental shape of the pass band.	
V.S.W.R in Pass Band	The ratio of the maximum value of a standing wave to its minimum value, related to the return loss in pass band.	

6. RELIABILITY TEST AND CONDITIONS

ITEM	TEST CONDITIONS	REQUIREMENTS
Resistance to solder heat	Preheat temperature : 120 to 150°C Preheat time: 1 to 1.5 min Solder temperature: 260 +/- 10°C Dipping time: 10 +/- 0.5 sec →Soldering Time : 5sec.max.per each terminal	No damage such as cracks should be caused in chip element.
Solderability	Preheat temperature: 120 to 150°C Preheat time: 1 to 1.5 min Solder temperature: 235 +/- 5°C Dipping time: 5 +/- 1 sec	More than 80% of the terminal electrode shall be covered with new solder
Heat resistance (High-temperature Load)	Temperature: 85 +/- 2°C Applied voltage: Rated voltage Applied current: Rated current Recovery: 1 to 2hrs of recovery under the standard condition after the removal from test chamber.	No mechanical damage. After test, the device shall satisfy the specification in section 3. Standard condition is 25+/-5°C and Less than 65% relative humidity
Thermal shock (Temperature cycle)	Conditions for 1 cycle Step 1: + 85°C 15 min Step 2 : - 44°C 15 min Number of cycle: 10	No mechanical damage. After test, the device shall satisfy the specification in section 3.
Humidity Resistance	Temperature: 40 +/- 2°C Humidity: 90 to 95% RH Duration: 96 +/- 5 hrs Recovery: 1 to 2hrs of recovery under the standard condition after the removal from test chamber.	No mechanical damage. After test, the device shall satisfy the specification in section 3.
Vibration	The device is subjected to vibration of 2 sweeps in each of three mutually perpendicular planes Frequency shall be varied within 10~50Hz with 1.5mm double amplitude and within 50~500 Hz With 10G's acceleration. Sweep time of Frequency Shall be 15minutes	No mechanical damage. After test, the device shall satisfy the specification in section 3.
Shock	The device is subjected to 3 shocks in each direction of six mutually perpendicular planes Each shock shall be a half-sine wave shaped with a magnitude of 30G's and a duration of 11msec.	No mechanical damage. After test, the device shall satisfy the specification in section 3.

7. REFLOW SOLDERING STANDARD CONDITIONS FOR TIN/LEAD

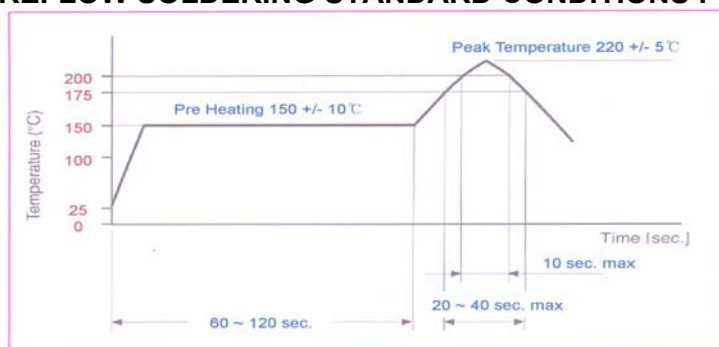

- Measuring point of temperature in-out terminals of the device.
- Reflow Soldering
- Both convection and infrared rays
- Hot air
- Hot plates
- Solder Cream: Sn64/Pb36