

SPECIFICATION

ITEM: LC BAND PASS FILTER
 PART NUMBER: FN-4680W

ISSUED / REVISION	ENGINEER APPROVED	DOCUMENT CHECKED	DRAFTSMAN
02/27/2020 ^(PG)	02/27/2020 ^(TG)	02/27/2020 ^(JE)	02/27/2020 ^(PG)

FILTRONETICS Inc

1. Part Number: FN-4680W

2. Electrical Specifications:

Filter Type		Band Pass
Center Frequency (Fo)		90 MHz
1 dB Band Width:		40 MHz Min
3 dB Band Width:		56 MHz Min
Insertion Loss:		2 dB Max
Pass Band Ripple:		1 dB Max
Attenuation:	At 40 MHz	60 dB Min
	At 140 MHz	
Input Power:		0 dBm Max
Impedance:		50 Ohms
Operating Temperature:		-20° to +70° C
Workmanship:		J-STD-001

3. Example Mechanical Package Styles:

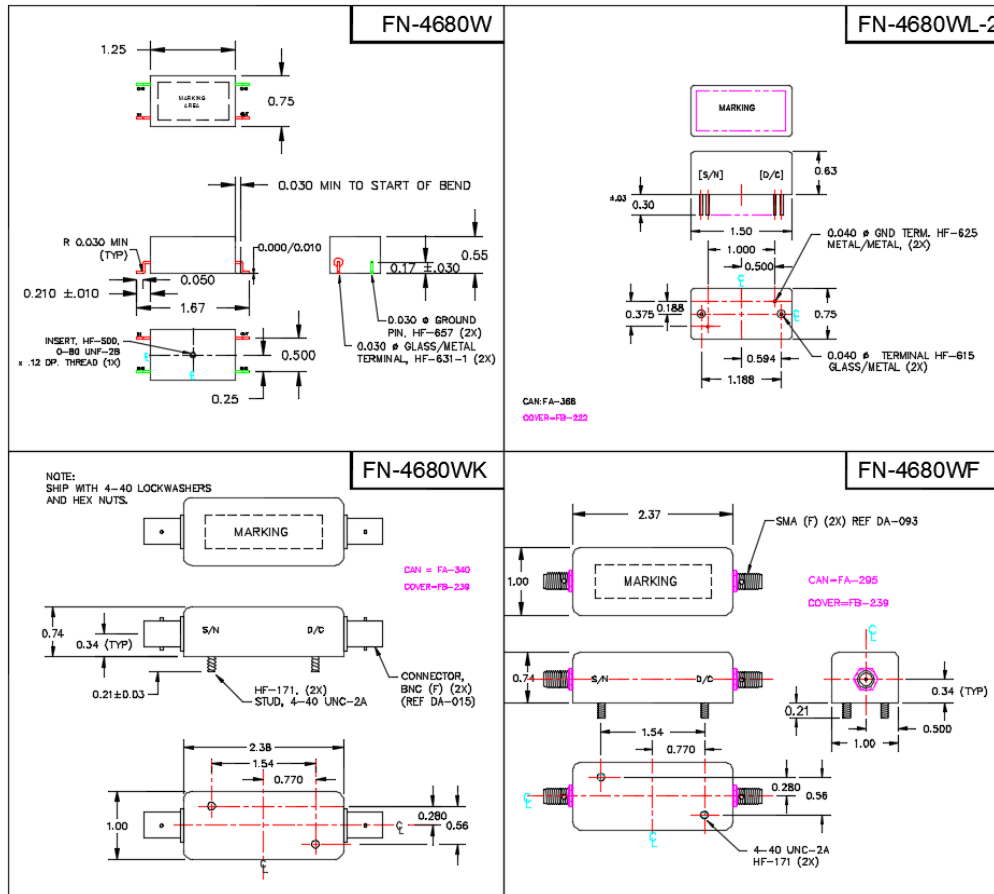

4. Theoretical Response Plots:

