

**FN-3623WS**

**BANDPASS FILTER**

Fo: 21.4 MHz  
 IMPEDANCE: 50 OHMS (IN & OUT)  
 INSERTION LOSS: 10 dB MAX  
 RIPPLE: 2 dB MAX  
 3dB BANDWIDTH: ± 125 KHz MIN  
 @ Fo ± 180 KHz: 60 dB MIN, 70 dB TYP.  
 ULTIMATE ATTEN.: 70dB NOM. to 100MHz  
 SPURIOUS ATTEN: 55 dB MIN  
 OPERATING TEMPERATURE: -40°C to +80°C

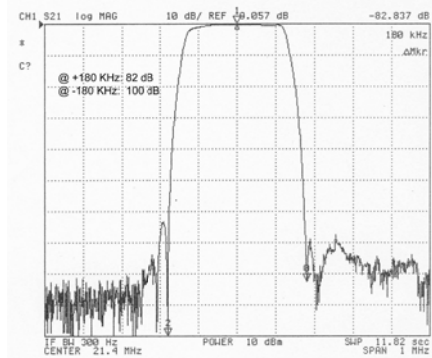

**FN-3623W DRAWING SUMMARY**

**FILTRONETICS, INC.**  
 6010 PARRETTA DR.  
 KANSAS CITY, MO 64120  
 816-231-7375  
 FAX 816-241-0368  
 WWW.FILTRO.NET

TOLERANCES UNLESS NOTED

.XX = ± .020  
 .XXX = ± .010

ANGLE = ± 1°  
 HOLES = ± .002

REVISED 4/19/2010

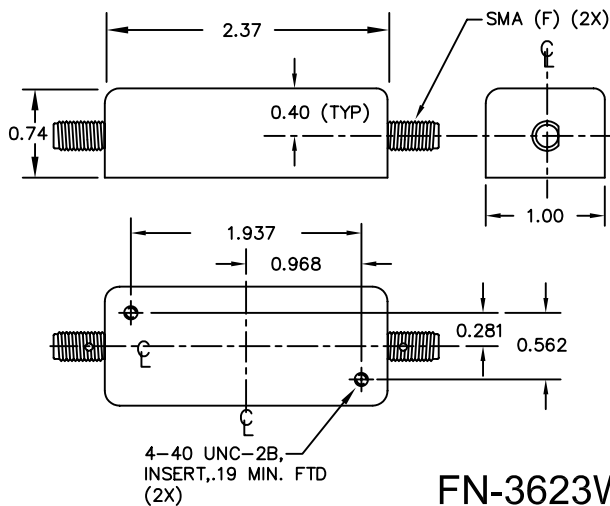

**FN-3623WJ**

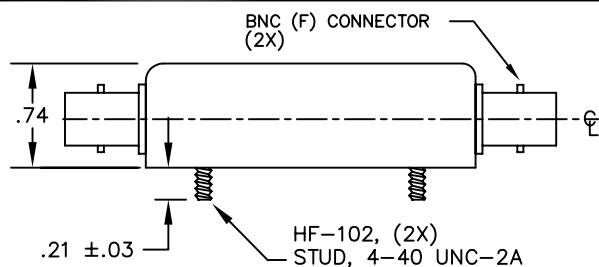

**FN-3623WK**

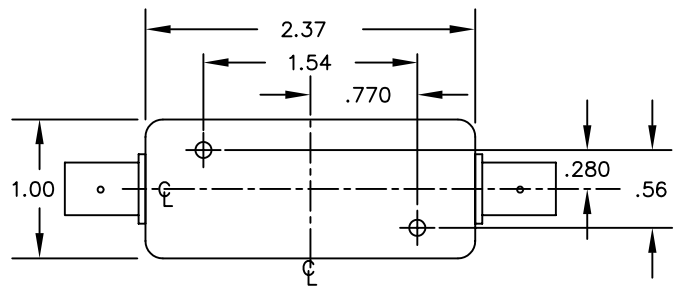

**FN-3623WK**

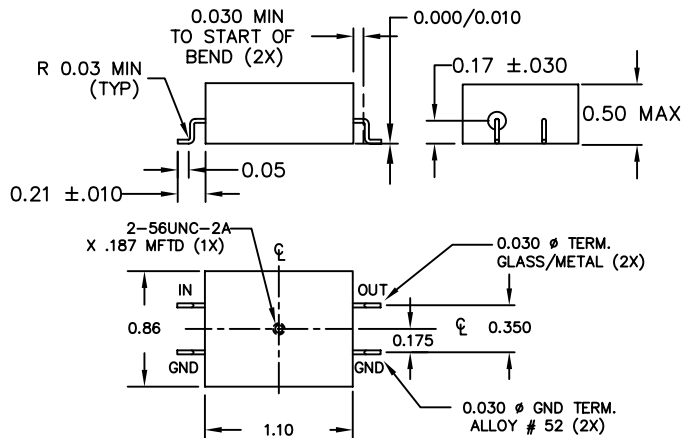

**FN-3623W**