

# SPECIFICATION

ITEM: DIELECTRIC CERAMIC FILTER

PART NUMBER: CFM-35350303

RoHs Compliant

Rev A 11/18/05 : ATTENUATION AT 3399 ~ 3429 MHz, 30 dBc Min → 27 dBc Min

ISSUED / REVISION	ENGINEER APPROVED	DOCUMENT CHECKED	DRAFTSMAN	DOCUMENT CHECKED
11/2005XX	03/19/2012 TFG		03/19/2012 GL	

**FILTRONETICS Inc**

1. APPLICATION

THIS SPECIFICATION APPLIES TO A BAND PASS FILTER USING DIELECTRIC RESONATORS.

2. PART NUMBER

PART NO	CFM-35350303
PACKAGING	Tape and Reel 1,500 / Plastic tray for small qty

3. SPECIFICATIONS

NO	ITEMS		DOWNLINK
1	Center Frequency (Fo)	a1	3535 MHz
2	Pass Bandwidth (BW)	b1	30 MHz (3520 ~ 3550 MHz)
3	Insertion Loss in BW	c1	3.0 dB Max
4	Ripple in BW	d1	0.5 dB Max
5	V.S.W.R in BW	i1	1.5 Max
6	Attenuation	At DC ~ 2500 MHz	35 dBc Min
		At 3036 ~ 3066 MHz	40 dBc Min
		At 3278 ~ 3308 MHz	35 dBc Min
		At 3399 ~ 3429 MHz	27 dBc Min
		At 3420 ~ 3450 MHz	20 dBc Min
		At 4000 MHz	35 dBc Min
7	Impedance		50 Ohms
8	Power Rating		1 W Max
9	Operating Temperature		- 40 to + 85 °C

S21 LOG MAG NETWORK ANALYZER

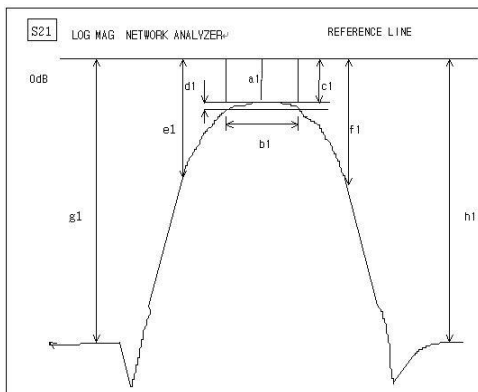

S11 LOG MAG NETWORK ANALYZER

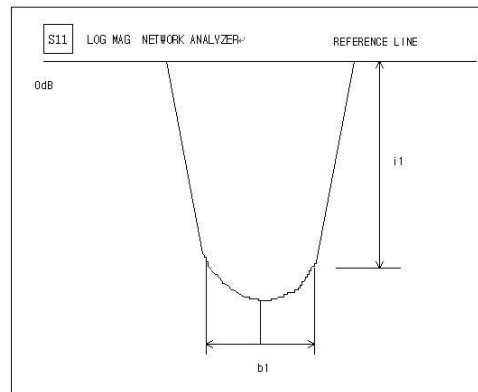

4. GRAPHS S21 & S11 (INSERTION LOSS, V.S.W.R)

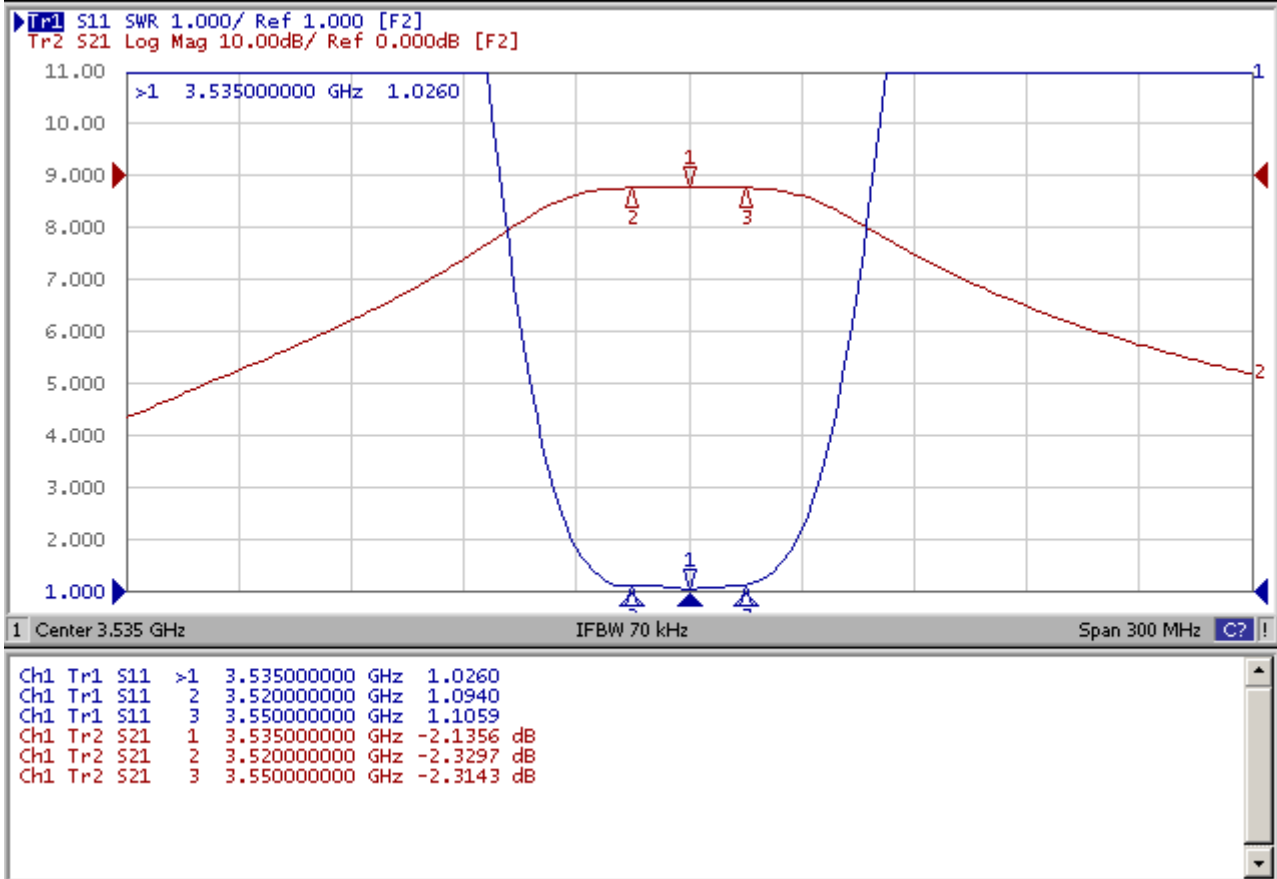

S21 & S11 (RIPPLE)

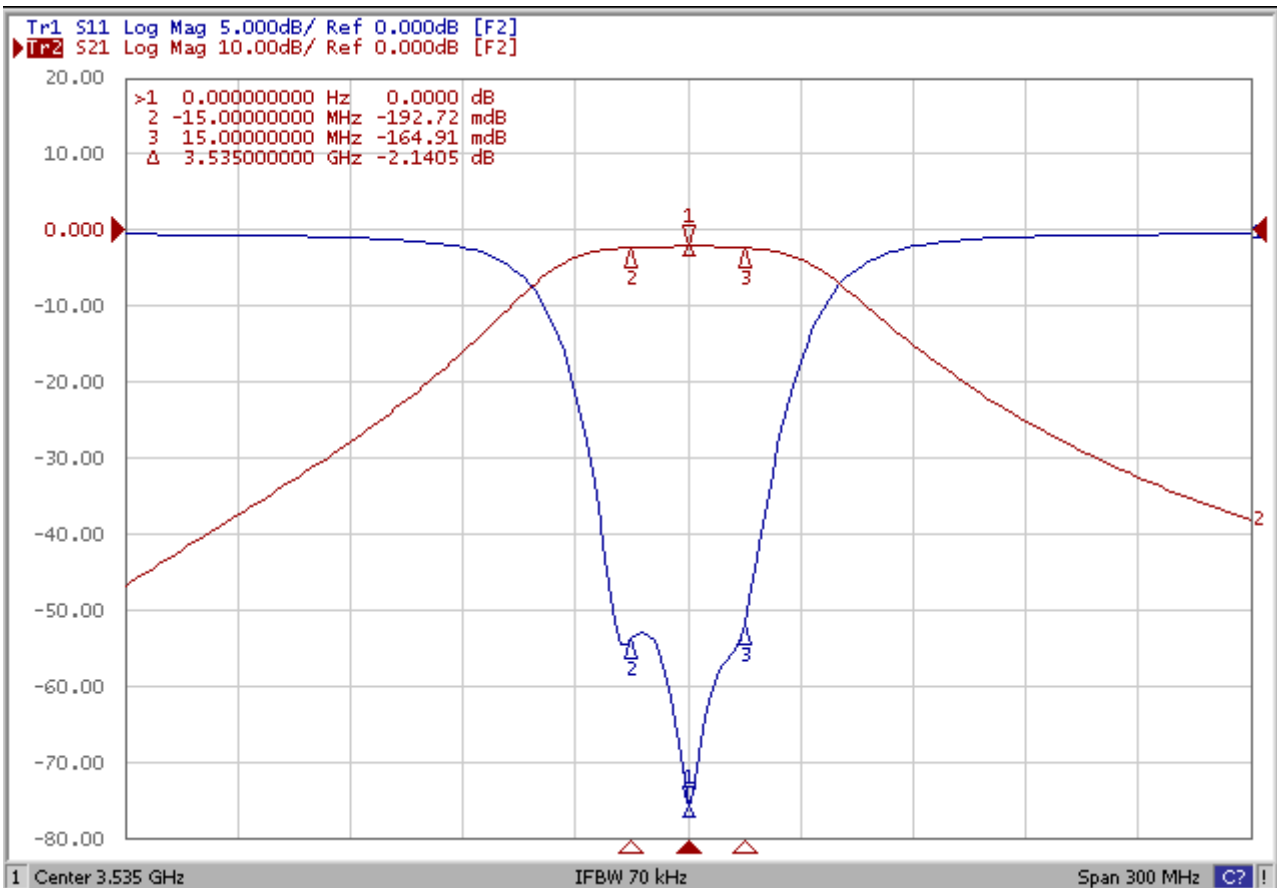

S21 & S11 (ATTENUATION AT 3278, 3308, 3399, 3429 MHz)

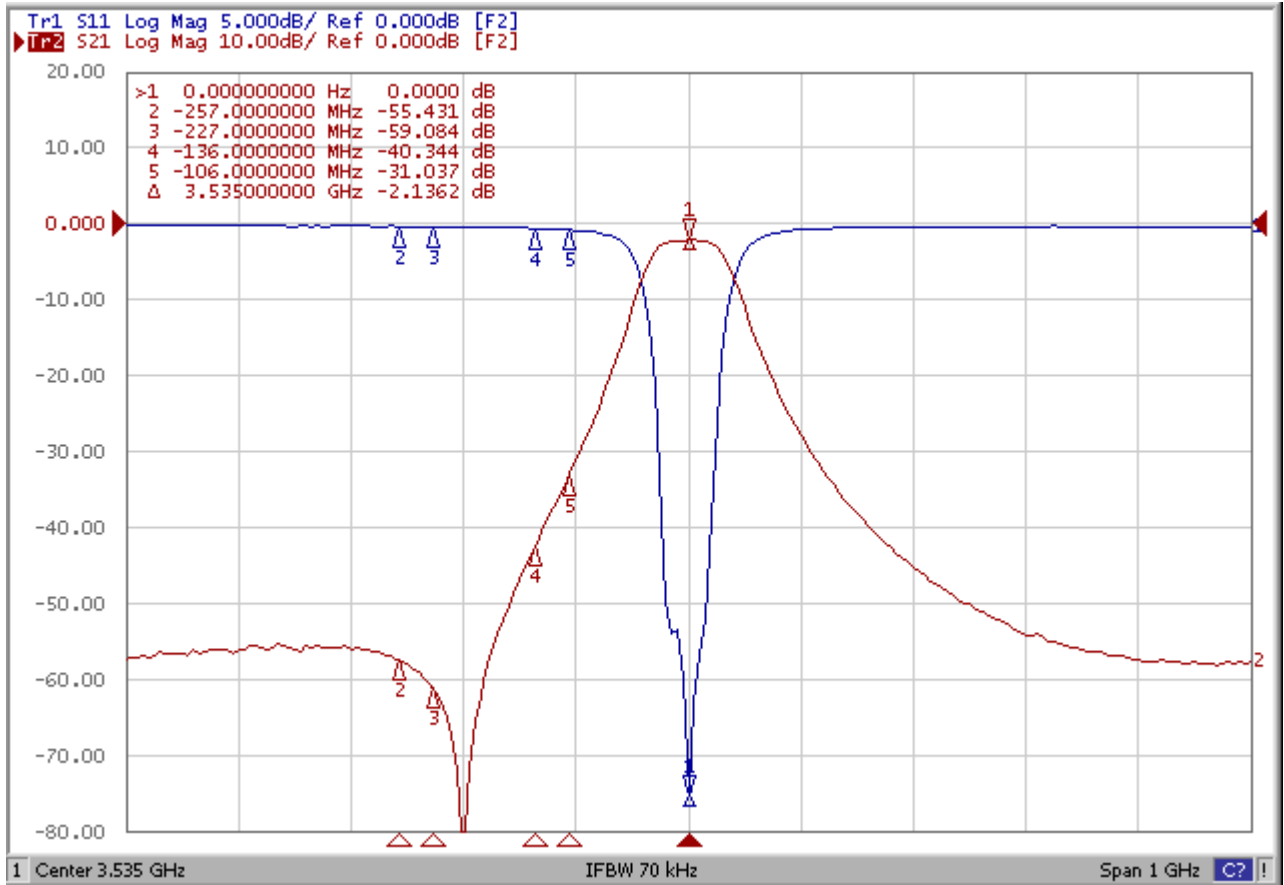

S21 & S11 (ATTENUATION AT 3420, 3450 MHz)

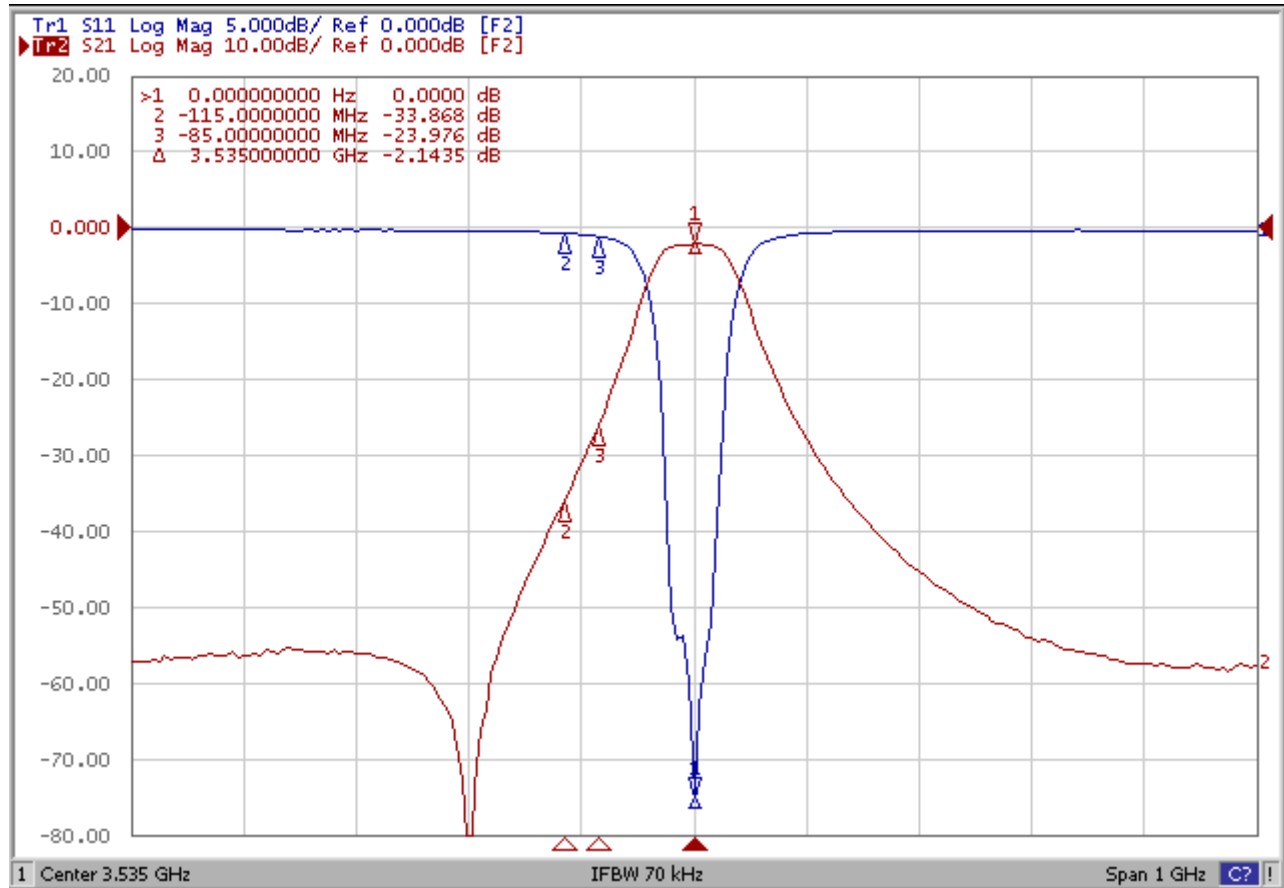

S21 & S11 (ATTENUATION AT 2500, 3036, 3066, 4000 MHz)

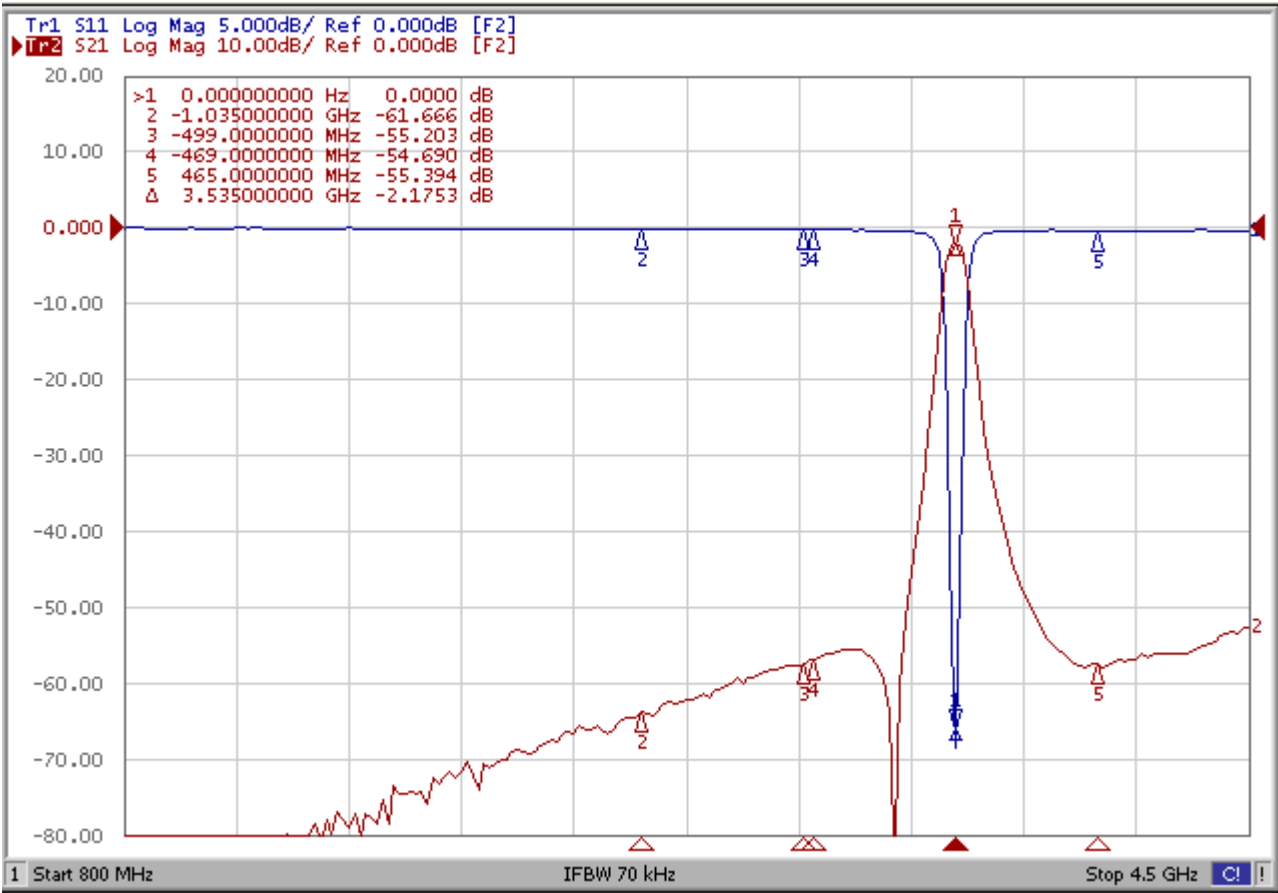

5. DIMENSIONS

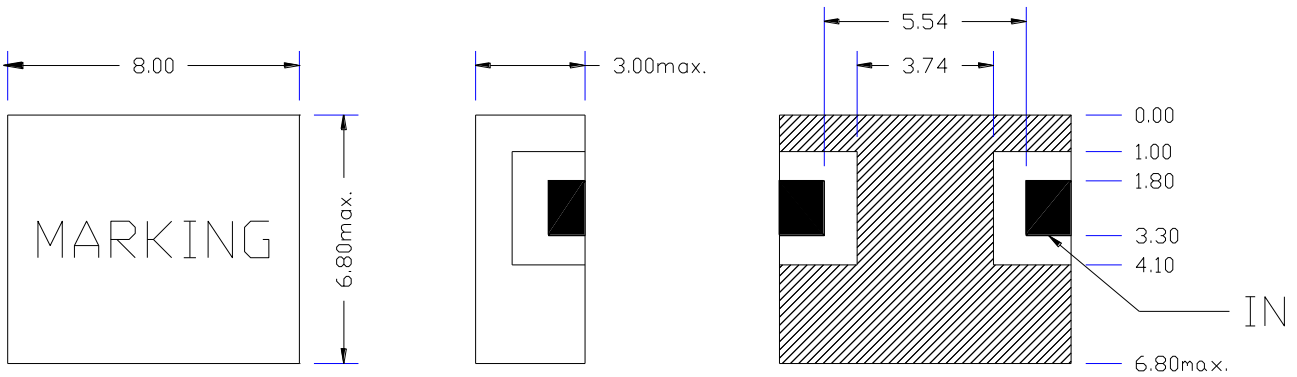

※ MATERIAL SPECIFICATION

RESONATOR  
 COATING MATERIAL: Ag  
 DIMENSION: 3MM 3POLE  
 RoHS Compliant

※ MARKING  
 CFM-35350303  
 DATE CODE

UNIT: MM  
 TOLERANCE: ±0.3MM

● CAUTIONS:

1. When handling products, be careful not to damage the outer-electrode.
2. When handling products be careful not to touch the outer-electrode with bare hands or solderability is reduced.
3. Do not apply excessive pressure or shock to product in handling or in transportation or damage to the ceramic filters may result.

**6. DEFINITIONS**

TERMS	DESCRIPTION	SPECIFICATION
Center Frequency	The midpoint of through band pass filter pass band, normally expressed as the arithmetic mean of the -3db point. Also called $f_0$ .	3. SPECIFICATION
Pass Band Width	The width of the pass band of a filter referenced to the minimum insertion loss point in the pass band. The pass band of a filter is stated as -1.0dB bandwidth.	
Insertion Loss	The loss of the filter, in db, measured at center frequency relative to a through line (0 dB).	
Attenuation	Reduction of RF power through a filter measured in dB, at desired band and referenced to 0 dB. (Filter to be removed from circuit)	
Pass Band Ripple	Variations in loss in the pass band of the filter, superimposed upon the fundamental shape of the pass band.	
V.S.W.R in Pass Band	The ratio of the maximum value of a standing wave to its minimum value, related to the return loss in pass band.	

7. RELIABILITY TEST AND CONDITIONS

ITEM	TEST CONDITIONS	REQUIREMENTS
Resistance to solder heat	Preheat temperature : 120 to 150°C Preheat time: 1 to 1.5 min Solder temperature: 260 +/- 10°C Dipping time: 10 +/- 0.5 sec	No damage such as cracks should be caused in chip element.
Solderability	Preheat temperature: 120 to 150°C Preheat time: 1 to 1.5 min Solder temperature: 235 +/- 5°C Dipping time: 5 +/- 1 sec	More than 80% of the terminal electrode shall be covered with new solder
Heat resistance (High-temperature Load)	Temperature: 85 +/- 2°C Applied voltage: Rated voltage Applied current: Rated current Recovery: 1 to 2hrs of recovery under the standard condition after the removal from test chamber.	No mechanical damage. After test, the device shall satisfy the specification in section 3.
Thermal shock (Temperature cycle)	Conditions for 1 cycle Step 1: + 85°C 15 min Step 2 : - 30°C 15 min Number of cycle: 10	No mechanical damage. After test, the device shall satisfy the specification in section 3.
Humidity Resistance	Temperature: 40 +/- 2°C Humidity: 90 to 95% RH Duration: 96 +/- 5 hrs Recovery: 1 to 2hrs of recovery under the standard condition after the removal from test chamber.	No mechanical damage. After test, the device shall satisfy the specification in section 3.
Vibration	Frequency: 10 ~ 50 Hz Amplitude: 1.52 mm ( 0.060 inches) Direction: X, Y and Z Time: each 30 min for all directions	No mechanical damage. After test, the device shall satisfy the specification in section 3.

8. REFLOW SOLDERING STANDARD CONDITIONS

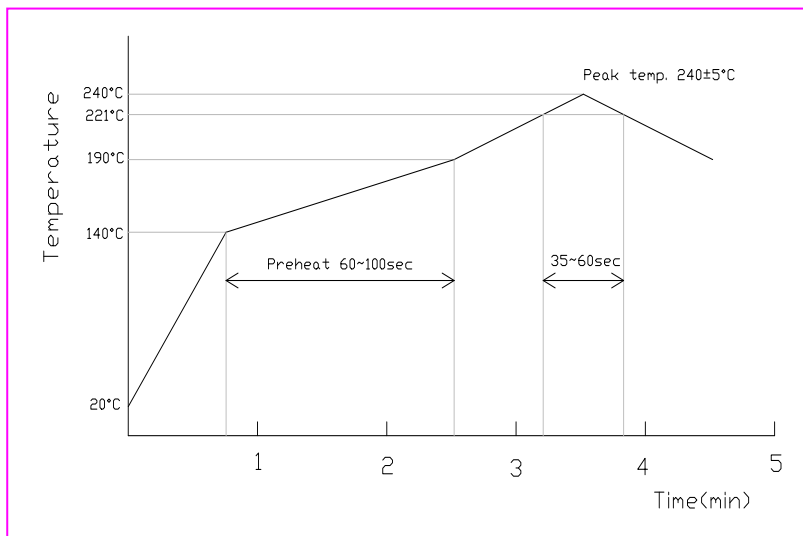

- Measuring point of temperature in-out terminals of the device.
- Reflow Soldering
- Both convection and infrared rays
- Hot air
- Solder Cream: Sn96.5/Ag3.5