

SPECIFICATION

ITEM: DIELECTRIC CERAMIC DIPLEXER
PART NUMBER: CFDM-3318339410

6/20/05 Packing:

Plastic Tray → Tape and Reel

Dimensions:

1. Filter Width:

40 mm ± 0.3 mm → 39.5 mm ± 0.3 mm

2. Filter Height:

5.72 mm MAX. → 6.1 mm ± 0.3 mm

3. Distance from Case to I/O electrode:

1.5 mm ± 0.3 mm → 1.8 mm ± 0.3 mm

| | | | | |
|--------|---------|---------|---------|----------|
| ISSUED | CHECKED | CHECKED | CHECKED | APPROVED |
| | | | | |

FILTRONETICS Inc

1. APPLICATION

THIS SPECIFICATION APPLIES TO A BAND PASS DIPLEXER USING DIELECTRIC RESONATORS.

2. PART NUMBER

| | |
|-----------|----------------------------|
| PART NO | CFDM-3318339410 |
| PACKAGING | Tape and Reel 400 per reel |

3. SPECIFICATIONS

| No | ITEMS | | TX -> ANT | ANT -> RX |
|----|---|--------------------|-------------------------------------|---------------------|
| 1 | Center Frequency (Fo) | a1 | 3318 MHz | 3394 MHz |
| 2 | Pass Band Width (BW) | b1 | 3312 ~ 3324 MHz | 3388 ~ 3400 MHz |
| 3 | Insertion Loss in BW | c1 | 3.0 dB (4.0 dB Max) | 3.0 dB (4.0 dB Max) |
| 4 | Ripple in BW | d1 | 1.0 dB Max | 1.0 dB Max |
| 5 | Return Loss in BW | i1 | 15.0 dB Min | 15.0 dB Min |
| 6 | Attenuation Is referenced to midband insertion loss. | DC ~ 2500 MHz | 35 dBc Min | 35 dBc Min |
| | | At 3242 ~ 3254 MHz | 15 dBc Min | - |
| | | At 2996 ~ 3008 MHz | 40 dBc Min | - |
| | | At 2680 ~ 2692 MHz | 45 dBc Min | - |
| | | At 3388 ~ 3400 MHz | 50 dB Min | - |
| | | At 4000 ~ 5000 MHz | 20 dB Min | 20 dB Min |
| | | At 6630 ~ 6642 MHz | 5 dBc Min | - |
| | | At 3215 ~ 3227 MHz | - | 35 dBc Min |
| | | At 2696 ~ 2708 MHz | - | 40 dBc Min |
| | At 3312 ~ 3324 MHz | - | 50 dB Min | |
| 7 | TX – RX Isolation | | 50 dB Min (3312-3324) - (3388-3400) | |
| 8 | Impedance | | 50 Ohms | 50 Ohms |
| 9 | Operating Temperature | | -40°C to +85°C | -40°C to +85°C |

S21 LOG MAG NETWORK ANALYZER

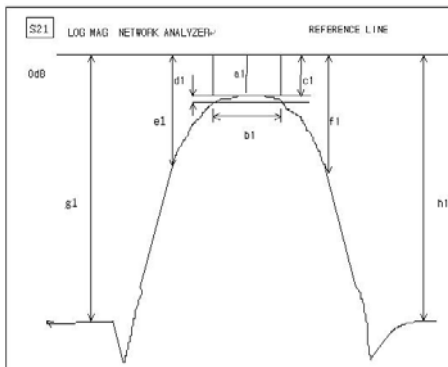

S11 LOG MAG NETWORK ANALYZER

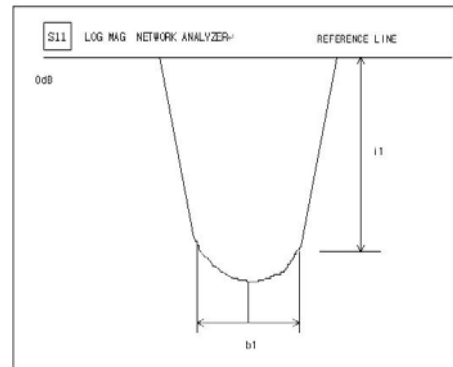

4. GRAPHS

S21 & S11 (TX PASS BAND)

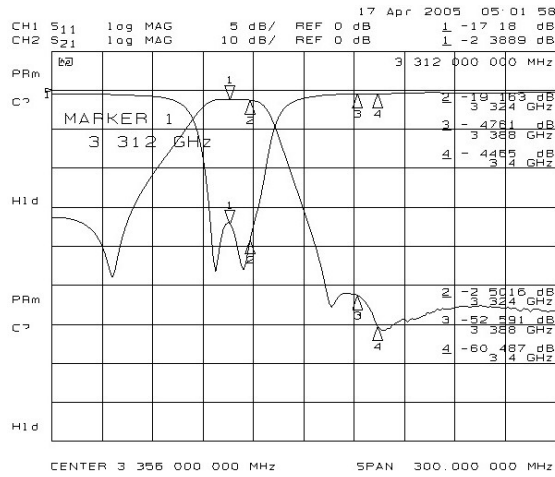

S21 & S11 (TX ATTENUATION AT DC TO 2500 MHz)

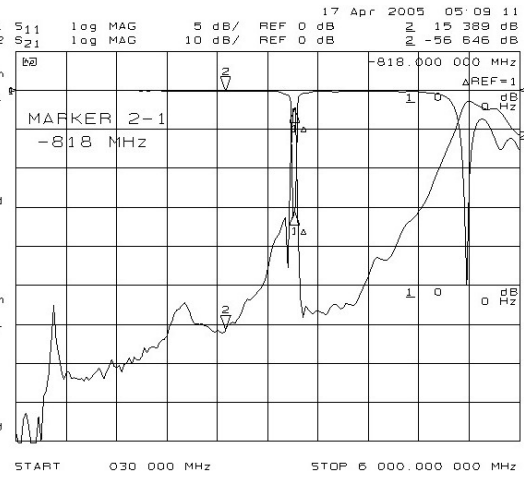

S21 & S11 (TX ATTENUATION AT 3242 TO 3254 MHz) S21 & S11 (TX ATTENUATION AT 2996 TO 3008 MHz)

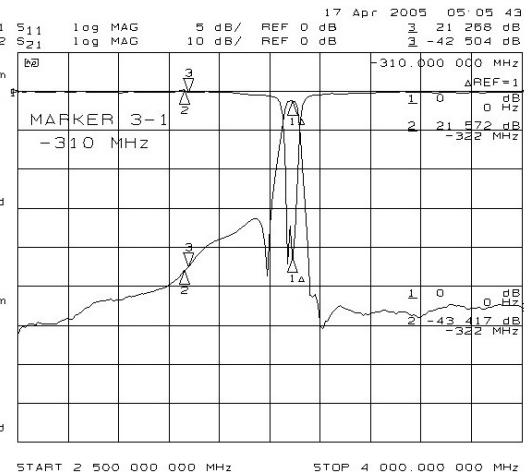
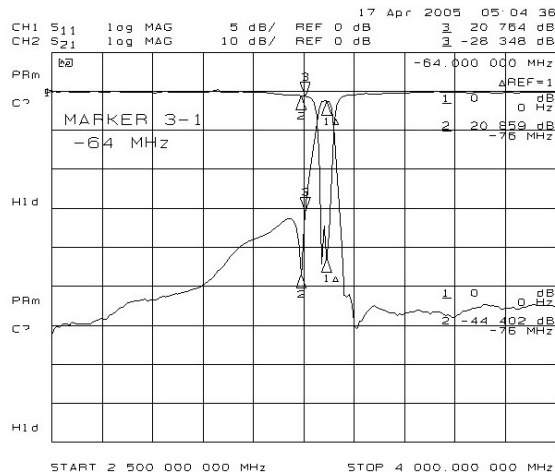

S21 & S11 (TX ATTENUATION AT 2680 TO 2692 MHz) S21 & S11 (TX ATTENUATION AT 4 TO 6 GHz)

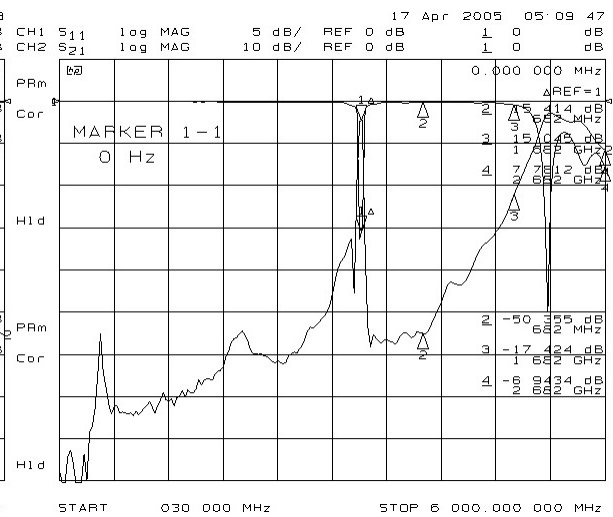
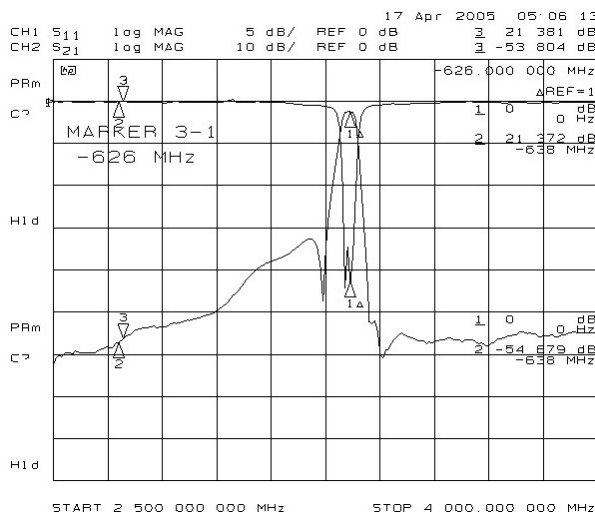

S21 & S11 (RX PASS BAND)

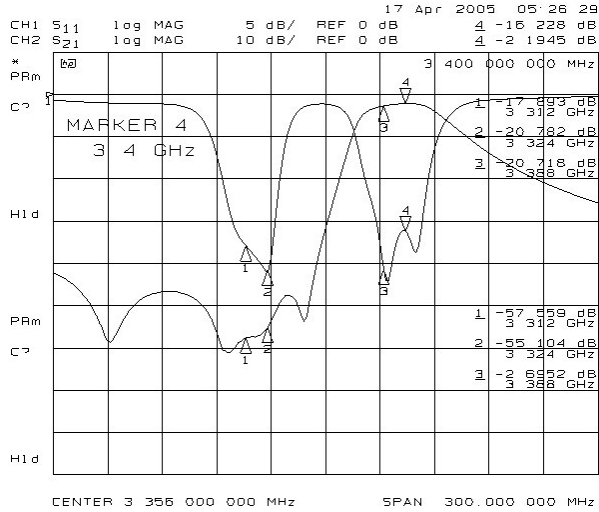

S21 & S11 (RX ATTENUATION AT DC TO 2500 MHz)

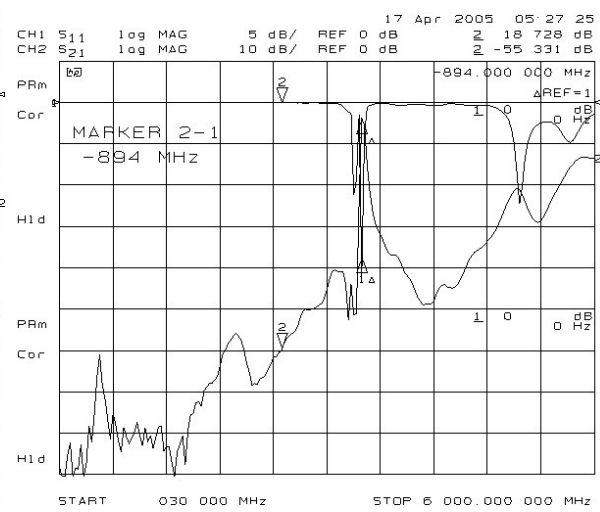

S21 & S11 (RX ATTENUATION AT 3215 TO 3227 MHz)

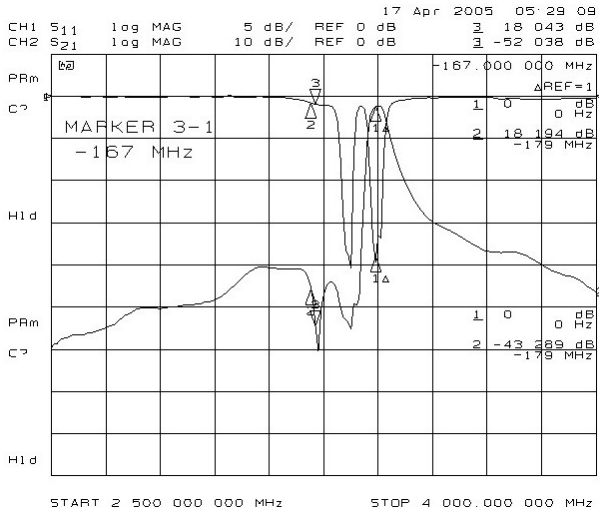

S21 & S11 (RX ATTENUATION AT 2696 TO 2708 MHz)

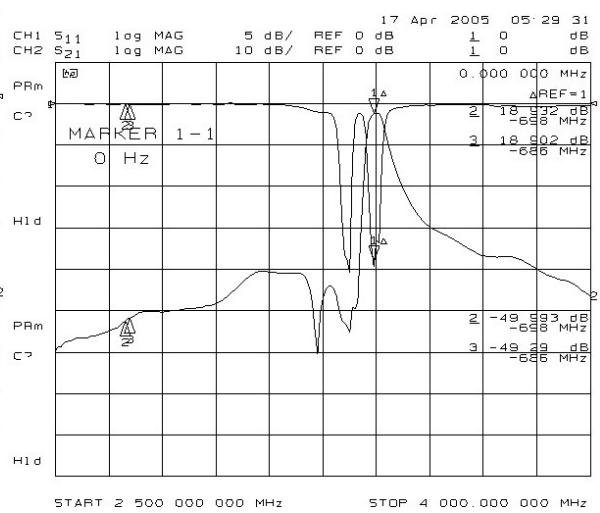

S21 & S11 (RX ATTENUATION AT 4 TO 6 GHz)

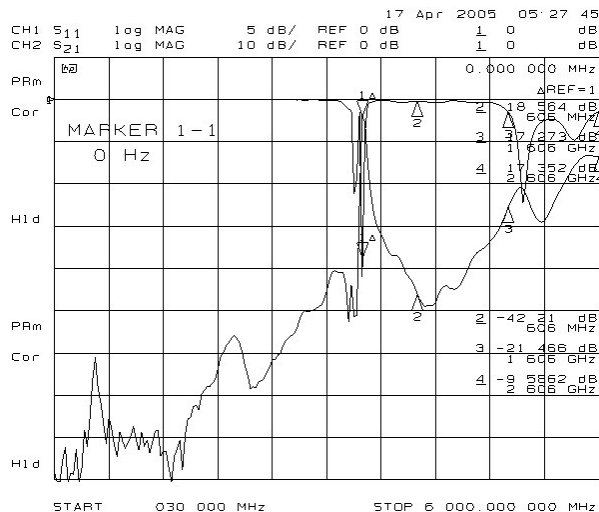

S21 (TX - RX ISOLATION)

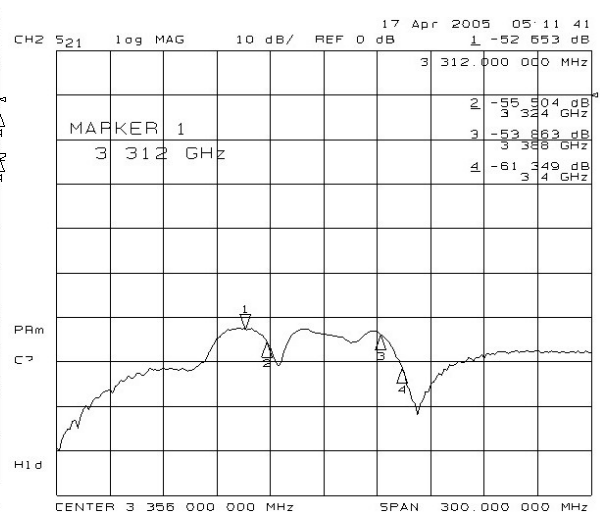

5. DIMENSIONS

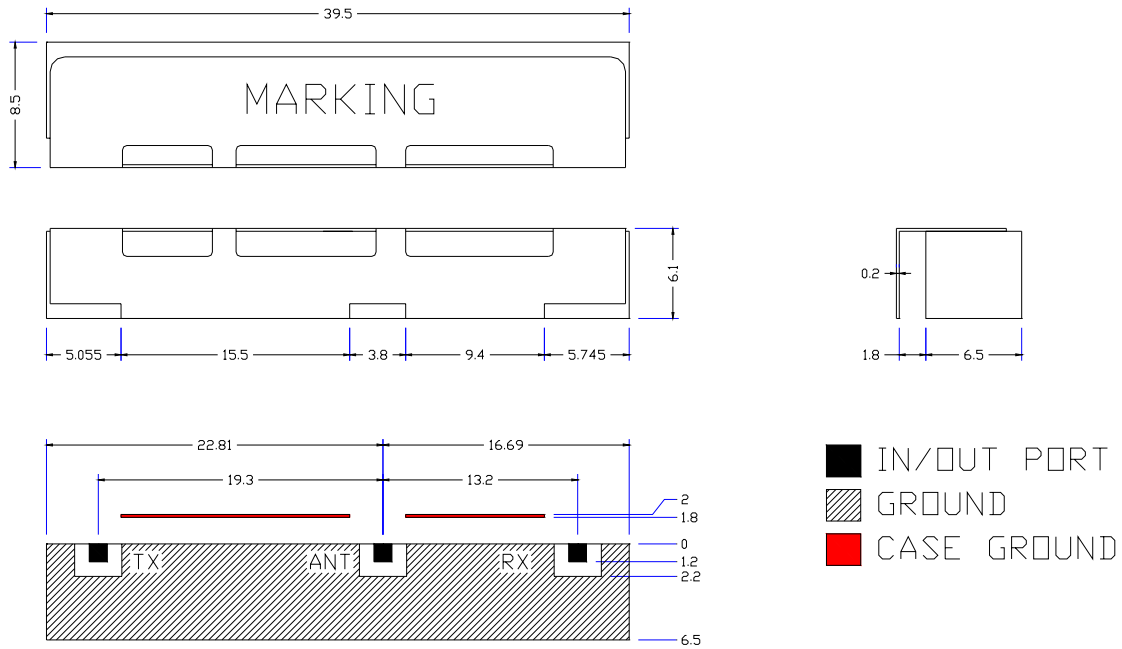

UNIT: MM

TOLERANCE: ±0.3MM

※ MATERIAL SPECIFICATION

- METAL CASE
 - MATERIAL: Sn OR Ni PLATED
- RESONATOR
 - COATING MATERIAL: Ag

※ MARKING

CFDM-3318339410

Filtronetics

Date Code

UNIT: MM

IN/OUT LAND :+/-0.3MM

● CAUTIONS:

- When handling products, be careful not to damage the outer-electrode.
- When handling products be careful not to touch the outer-electrode with bare hands or solderability is reduced.
- Do not apply excessive pressure or shock to product in handling or in transportation or damage to the ceramic filters may result.

6. DEFINITIONS

| TERMS | DESCRIPTION | SPECIFICATION |
|----------------------|--|---------------------|
| Center Frequency | The midpoint of through band pass filter pass band, normally expressed as the arithmetic mean of the -3db point. Also called f_0 . | 3. SPECIFICATION |
| Pass Band Width | The width of the pass band of a filter referenced to the minimum insertion loss point in the pass band. The pass band of a filter is stated as -1.0dB bandwidth. | |
| Insertion Loss | The loss of the filter, in db, measured at center frequency relative to a through line (0 dB). | |
| Attenuation | Reduction of RF power through a filter measured in dB, at desired band and referenced to 0 dB. (Filter to be removed from circuit) | |
| Pass Band Ripple | Variations in loss in the pass band of the filter, superimposed upon the fundamental shape of the pass band. | |
| V.S.W.R in Pass Band | The ratio of the maximum value of a standing wave to its minimum value, related to the return loss in pass band. | |

7. RELIABILITY TEST AND CONDITIONS

| ITEM | TEST CONDITIONS | REQUIREMENTS |
|---|--|--|
| Resistance to solder heat | Preheat temperature : 120 to 150°C Preheat time: 1 to 1.5 min Solder temperature: 260 +/- 10°C Dipping time: 10 +/- 0.5 sec | No damage such as cracks should be caused in chip element. |
| Solderability | Preheat temperature: 120 to 150°C Preheat time: 1 to 1.5 min Solder temperature: 235 +/- 5°C Dipping time: 5 +/- 1 sec | More than 80% of the terminal electrode shall be covered with new solder |
| Heat resistance (High-temperature Load) | Temperature: 85 +/- 2°C Applied voltage: Rated voltage Applied current: Rated current Recovery: 1 to 2hrs of recovery under the standard condition after the removal from test chamber. | No mechanical damage. After test, the device shall satisfy the specification in section 3. |
| Thermal shock (Temperature cycle) | Conditions for 1 cycle Step 1: + 85°C 15 min Step 2 : - 30°C 15 min Number of cycle: 10 | No mechanical damage. After test, the device shall satisfy the specification in section 3. |
| Humidity Resistance | Temperature: 40 +/- 2°C Humidity: 90 to 95% RH Duration: 96 +/- 5 hrs Recovery: 1 to 2hrs of recovery under the standard condition after the removal from test chamber. | No mechanical damage. After test, the device shall satisfy the specification in section 3. |
| Vibration | Frequency: 10 ~ 50 Hz Amplitude: 1.52 mm (0.060 inches) Direction: X, Y and Z Time: each 30 min for all directions | No mechanical damage. After test, the device shall satisfy the specification in section 3. |

8. REFLOW SOLDERING STANDARD CONDITIONS

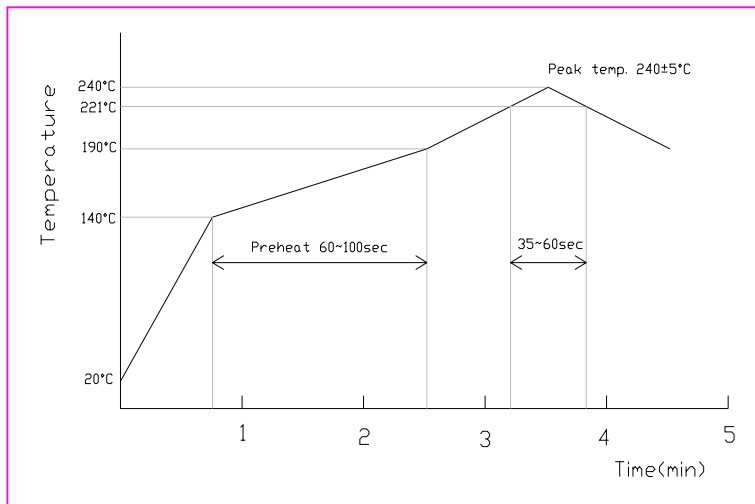

- Measuring point of temperature in-out terminals of the device.
- Reflow Soldering
- Both convection and infrared rays
- Hot air
- Solder Cream: Sn96.5/Ag3.5