

SPECIFICATION

COMMERCIALY AVAILABLE

CERAMIC BAND PASS
PART NUMBER: CF-27181627

RoHS

ISSUED / REVISION	ENGINEER APPROVED	DOCUMENT CHECKED	DRAFTSMAN	DOCUMENT CHECKED
3/13/18 ^(kn)				

FILTRONETICS Inc

1. APPLICATION

THIS SPECIFICATION APPLIES TO A BAND PASS FILTER, USING DIELECTRIC RESONATORS.

2. PART NUMBER:

PART NO	CF-27181627
PACKAGING	PLASTIC TRAY

3. SPECIFICATIONS:

NO	ITEMS	Ref.	SPECIFICATION
1	Center Frequency (Fo)	-	2718 MHz
2	Pass Band Width(=PB)	-	2637.5~2800 MHz
3	Insertion Loss AT Fo	-	2.8 dB Max
4	Ripple IN PB	-	1.0 dB Max
5	1dB Band Width		250Max
6	60dB Band Width		545Max
7	Return Loss IN PB	-	10dB Min
8	Impedance	-	50Ω
9	Maximum Input Power	-	1 W (+30dBm)
10	Operating Temperature Range	-	-30 - +75°C

S21 LOG MAG NETWORK ANALYZER

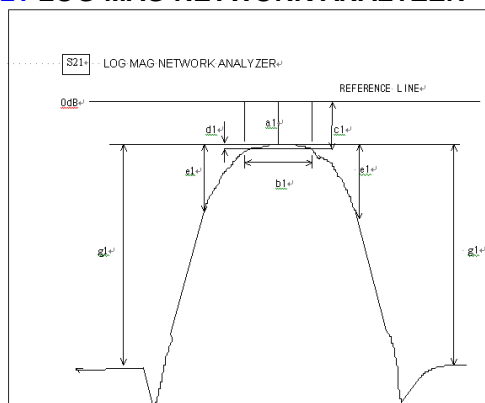

S11 LOG MAG NETWORK ANALYZER

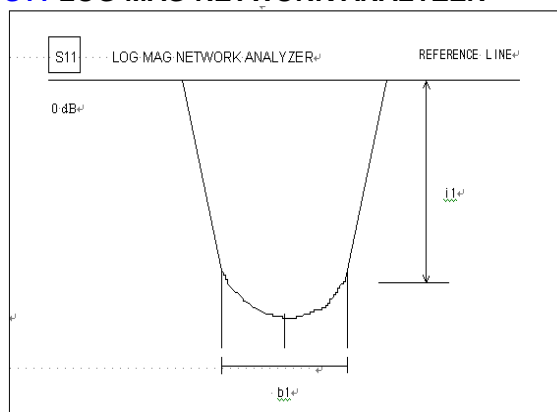

4. DIMENSIONS:

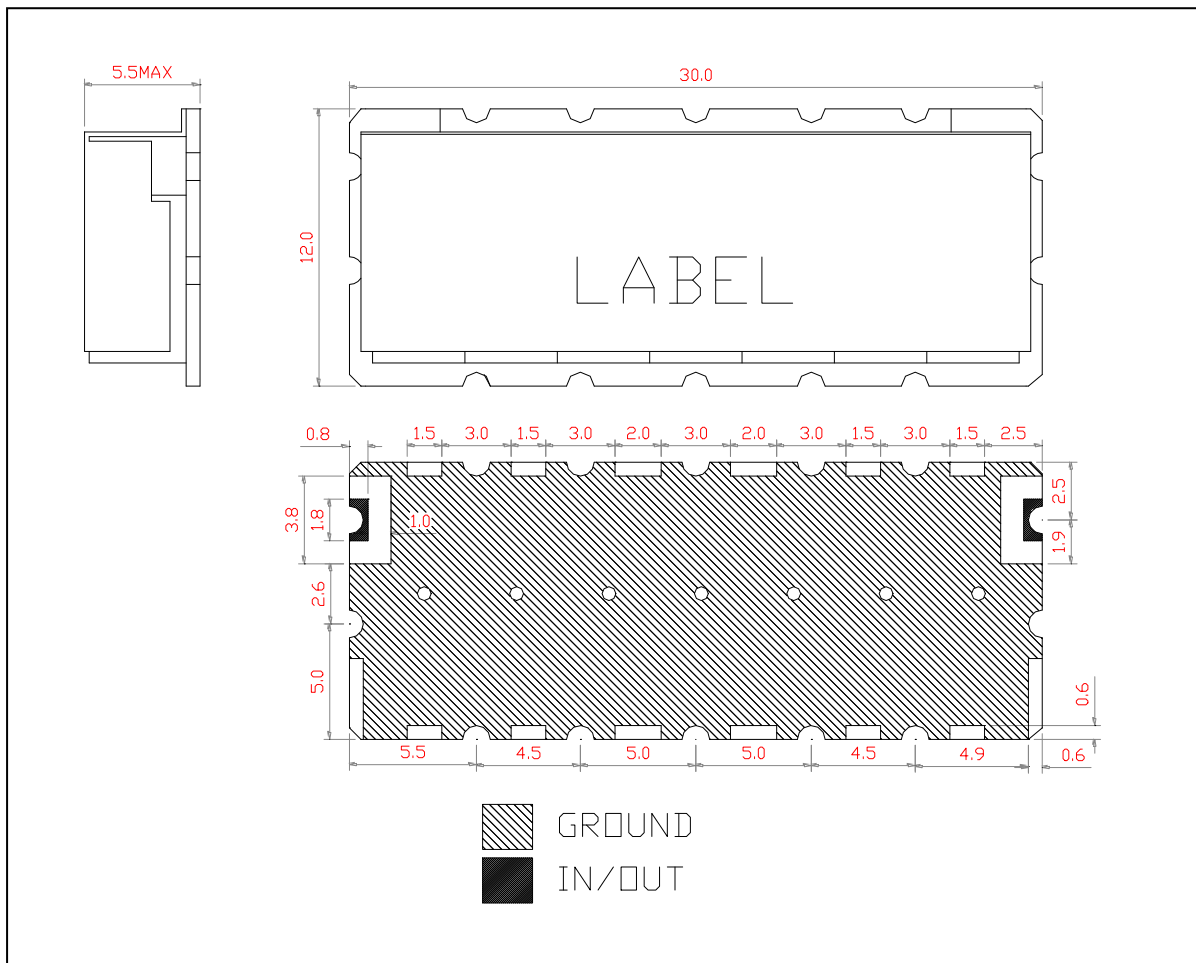

Mechanical Specification

1. Resonators: Dielectric Resonator
2. Number of Poles: 7 poles
3. Resonator Size: 4mm X 4mm
4. PCB Material: FR-4
5. Input/output Terminals: Au Plated
6. Cover Material: Brass(Tin plated)
7. RoHS Compliant.

Note: The number of through holes may be changed without notice.

MARKING

Part No
Date Code

UNIT: MM
TOLERANCE: +/-0.5MM
IN/OUT LAND: +/-0.3MM

CAUTIONS:

1. When handling products, be careful not to damage the outer-electrode.
2. When handling products be careful not to touch the outer-electrode with bare hands or solderability is reduced.
3. Do not apply excessive pressure or shock to product in handling or in transportation or damage to the ceramic filters may result.

5. SIMULATION GRAPH:

S21 vs S11 (INSERTION LOSS, RETURN LOSS, V.S.W.R, SMITH CHART)

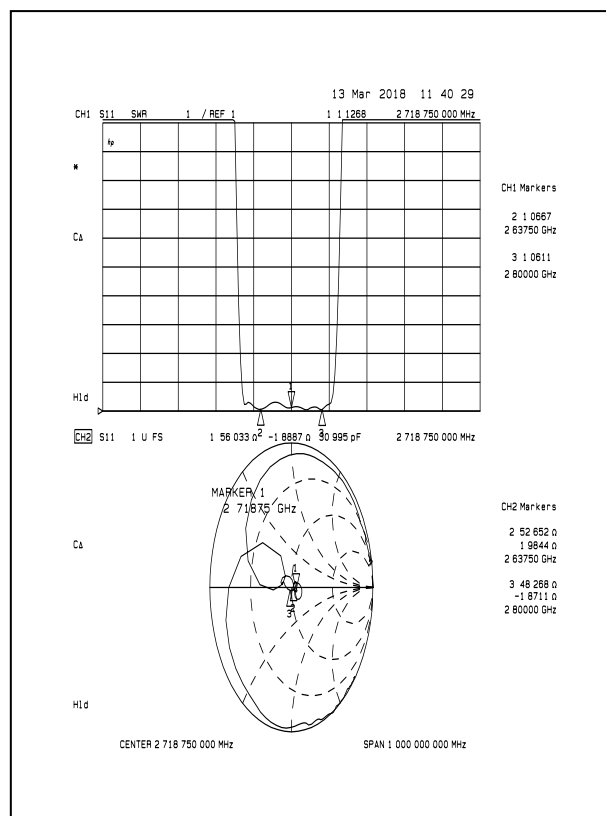
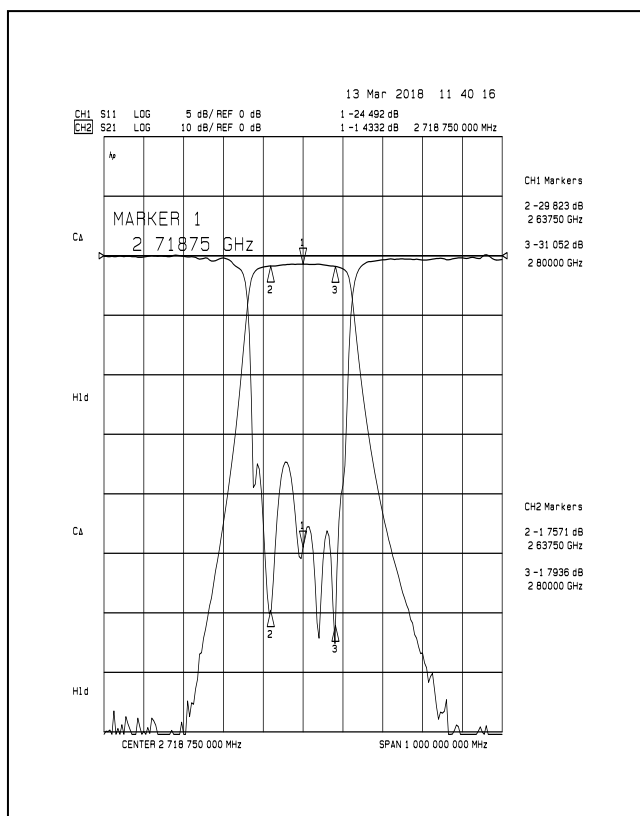

S21 (1dB BAND WIDTH, 60dB BAND WIDTH)

