

SPECIFICATION
COMMERCIALY AVAILABLE

ITEM: CERAMIC BAND PASS
 PART NUMBER:CF-26800265
 RoHS

01/29/2021- Revised mechanical dimensions.

ISSUED	CHECKED	CHECKED	CHECKED
7/23/09 kn	6/1/2010 SRJ	6/1/2010 BF	6/1/2010 GL
7/18/13 ^(kn)			
01/29/2021 ^(ASM)			

FILTRONETICS Inc

1. APPLICATION

THIS SPECIFICATION APPLIES TO BAND PASS FILTER, USING DIELECTRIC RESONATORS.

2. PART NUMBER: CF-26800265

3. SPECIFICATIONS

ITEMS		Ref.	SPECIFICATION
Center Frequency (Fo)		a1	2680 MHz
1.0 dB Band Width		-	26 MHz Min
Insertion Loss	IN Fo +/-13 MHz	-	5.5 dB Max
Attenuation [Absolute Value]	At 2610 MHz	-	50 dB Min
	-	-	-
V.S.W.R	IN Fo +/-13 MHz	-	1.5 : 1 Max
Impedance		-	50Ω
Maximum Input Power		-	1 W (+30 dBm)
Operating Temperature Range		-	-40 to +70 °C

S21 LOG MAG NETWORK ANALYZER

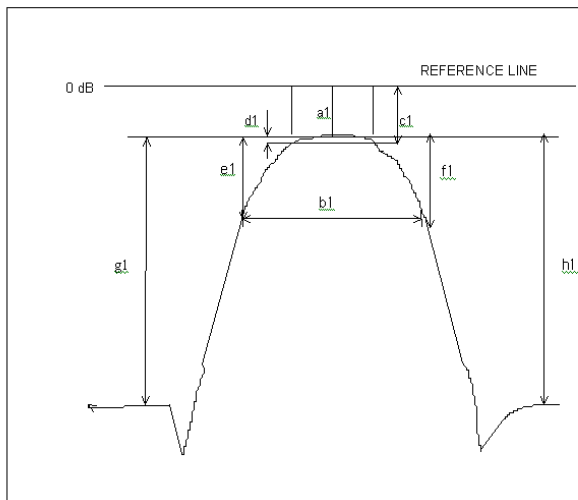

S11 SWR NETWORK ANALYZER

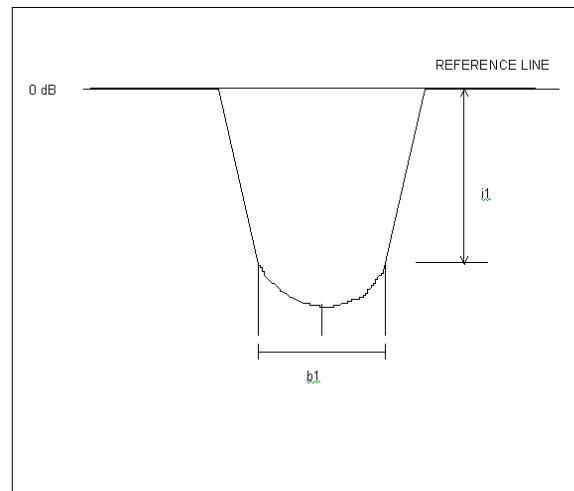

4. DIMENSIONS: (Revised B, 0-E, 0-F, 0-J, 0-K and L)

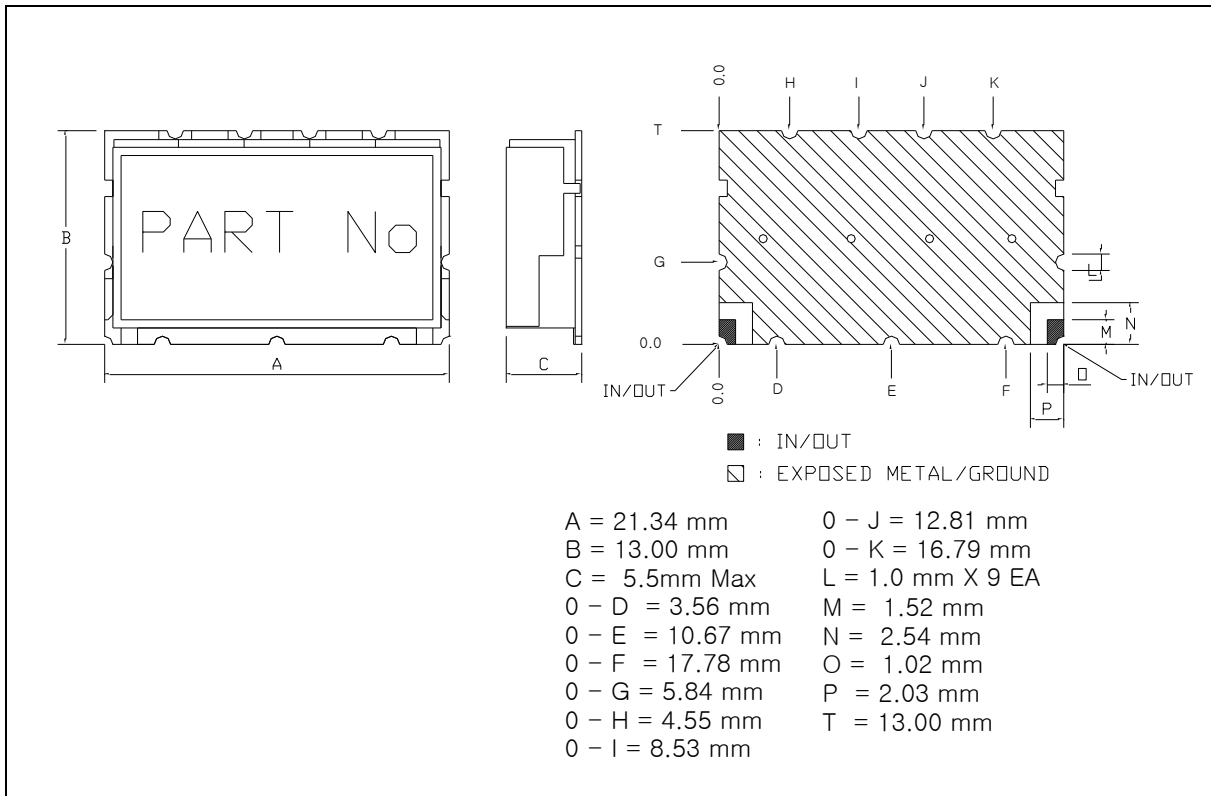

Mechanical Specification

1. PCB
 - 1) MATERIAL: FR-4
 - 2) TERMINALS: Au PLATED
2. METAL CASE
 - 1) MATERIAL: BRASS
 - 2) PLATING: Sn OR Ni PLATED
3. RESONATOR
 - 1) COATING MATERIAL: Ag
4. RoHS Compliant

Marking

Part No: CF-26800265

Filtronetics
Date Code

UNIT: mm
TOLERANCE: +/-0.5mm
IN/OUT LAND: +/-0.3mm

● CAUTIONS:

1. When handling products, be careful not to damage the outer-electrode.
2. When handling these products be careful not to touch the outer-electrode with bare hands or solder-ability is reduced.
3. Do not apply excessive pressure or shock to product in handling or in transportation or damage to the ceramic filters may result.

5. GRAPHS

S21 vs. S11 (INSERTION LOSS, RETURN LOSS, ATTENUATION, V.S.W.R, SMITH CHART)

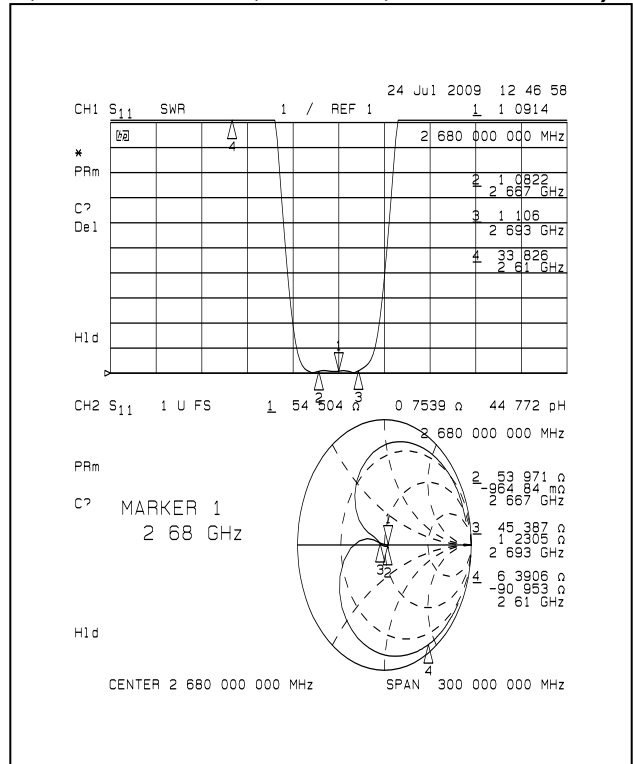
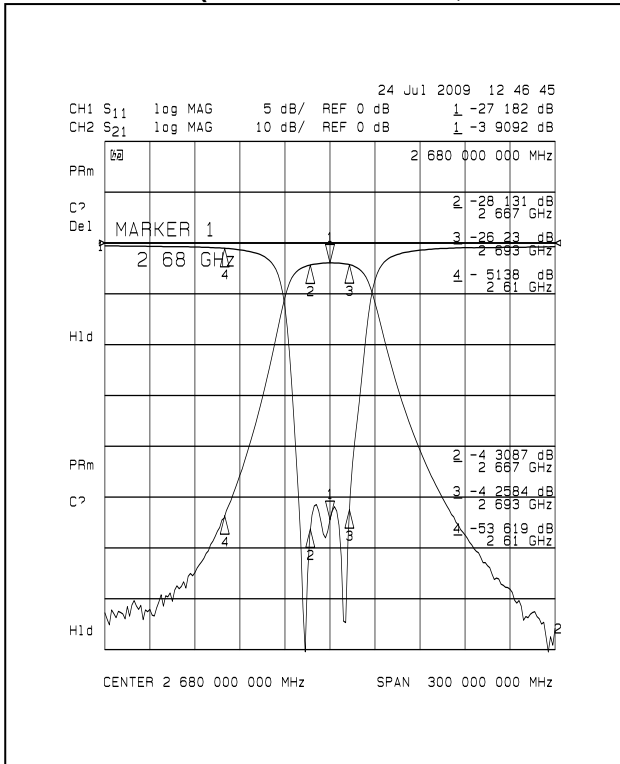

S21 (1.0dB BAND WIDTH, 50dB BAND WIDTH)

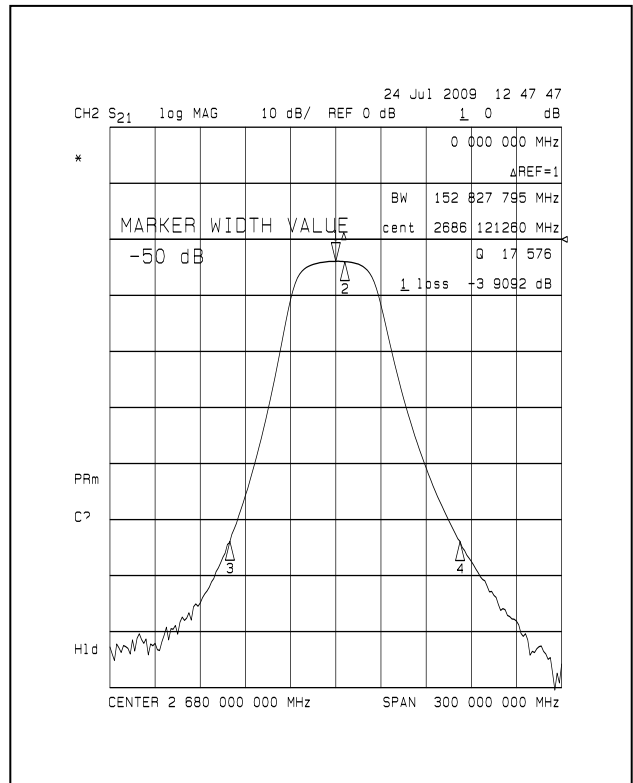
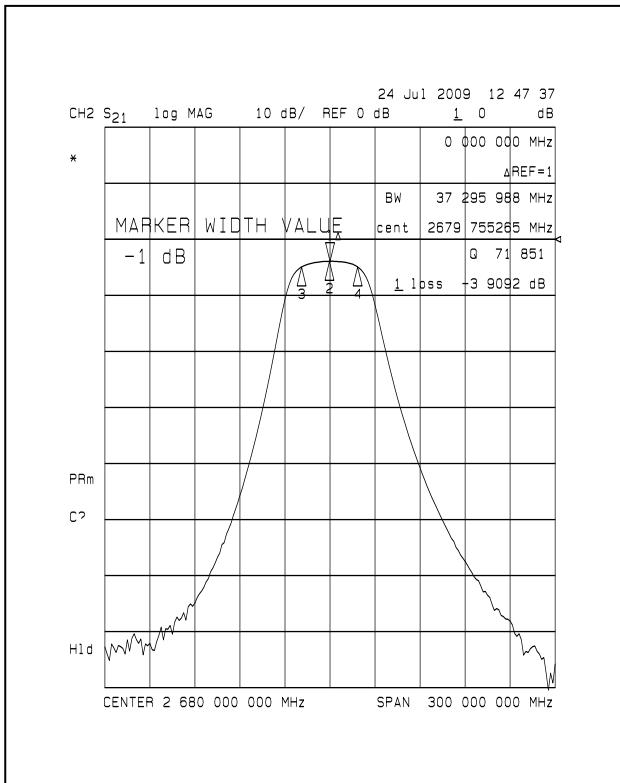

6. DEFINITIONS

TERMS	DESCRIPTION	SPECIFICATION
Center Frequency	The midpoint of through band pass filter pass band, normally expressed as the arithmetic mean of the -3dB point. Also called Fo.	3. SPECIFICATION
Pass Band Width	The width of the pass band of a filter referenced to the minimum insertion loss point in the pass band. The pass band of a filter is stated as -1.0dB bandwidth.	
Insertion Loss	The loss of the filter, in dB, measured at center frequency relative to a through line (0 dB).	
Attenuation	Reduction of RF power through a filter measured in dB, at desired band and referenced to 0 dB. (Filter to be removed from circuit)	
Pass Band Ripple	Variations in loss in the pass band of the filter, superimposed upon the fundamental shape of the pass band.	
V.S.W.R in Pass Band	The ratio of the maximum value of a standing wave to its minimum value, related to the return loss in pass band.	
Date Code	Each date code shall be from a single lot	
Lot	One Batch of parts processed in a single manufacturing run. A single lot shall have no more than one firing, plating, soldering, or other batch processing.	
Cleanliness	Parts shall be clean. They shall be free from smudges, loose solder, solder spatter, metal chips or mold release agents. No burrs. Particles or any foreign material over 0.2 mm which might detract from the intended operation, function or appearance of the part.	

7. REFLOW SOLDERING STANDARD CONDITIONS FOR RoHS

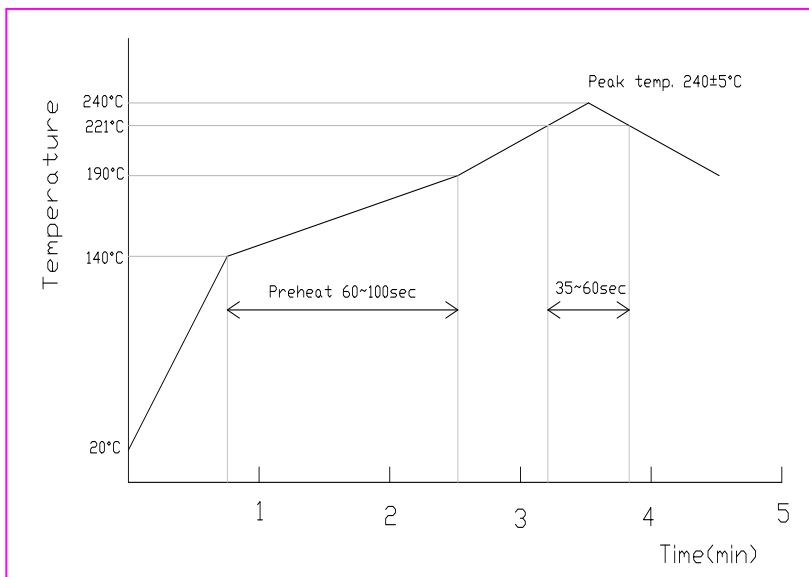

- Measuring point of temperature in-out terminals of the device.
- Reflow Soldering
- Both convection and infrared rays
- Hot air
- Hot plates
- Solder Cream: Sn96.5/Ag3.5