

SPECIFICATION

COMMERCIALY AVAILABLE

CERAMIC BAND PASS
PART NUMBER: CF-16750045M
RoHS

8/17/16 Updated Dimensional Drawing, Material Description, and reflow profile.
 Added marking & recommended footprint

ISSUED / REVISION	ENGINEER APPROVED	DOCUMENT CHECKED	DRAFTSMAN	DOCUMENT CHECKED
2/17/04 *	1/19/2011 SRJ	1/19/2011 BF	1/19/2011 GL	
3/13/12 DS	06/08/2012 TFG		06/08/2012 GL	
5/29/13 ^(kn)	06/03/2013 TFG		06/03/2013 GL	
8/17/16 ^(kn)				

FILTRONETICS Inc

1. APPLICATION

THIS SPECIFICATION APPLIES TO A BAND PASS FILTER, USING DIELECTRIC RESONATORS.

2. PART NUMBER:

PART NO	CF-16750045M
PACKING	PLASTIC TRAY

3. SPECIFICATIONS:

1	Center Frequency (Fo)	a1	1675 MHz	
2	Pass Band Width	b1	Fo +/-2 MHz Min	
3	Insertion Loss at Fo	c1	4.0 dB Max	
4	Ripple in PB	d1	0.35 dB Max	
5	Attenuation	DC to 1633 MHz	g1	40 dB Min
		1717 MHz to 3595 MHz	g1	40 dB Min
6	Return Loss in PB	i1	10 dB Min	
7	Impedance		50Ω	
8	Maximum Input Power		1 W (+30 dBm)	
9	Group Delay Time in PB		nSec Max	
10	Operating Temperature Range		-40 - +70 (°C)	

S21 LOG MAG NETWORK ANALYZER

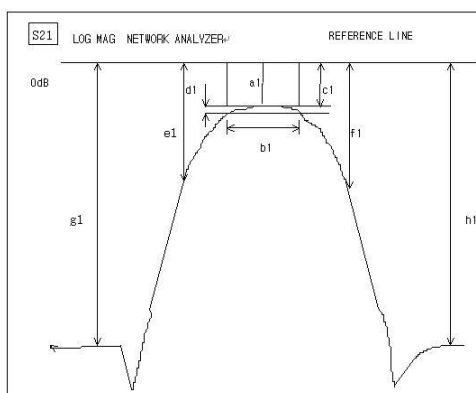

S11 LOG MAG NETWORK ANALYZER

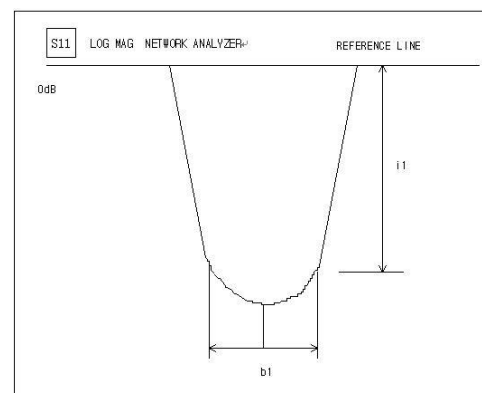

4. DIMENSIONS:

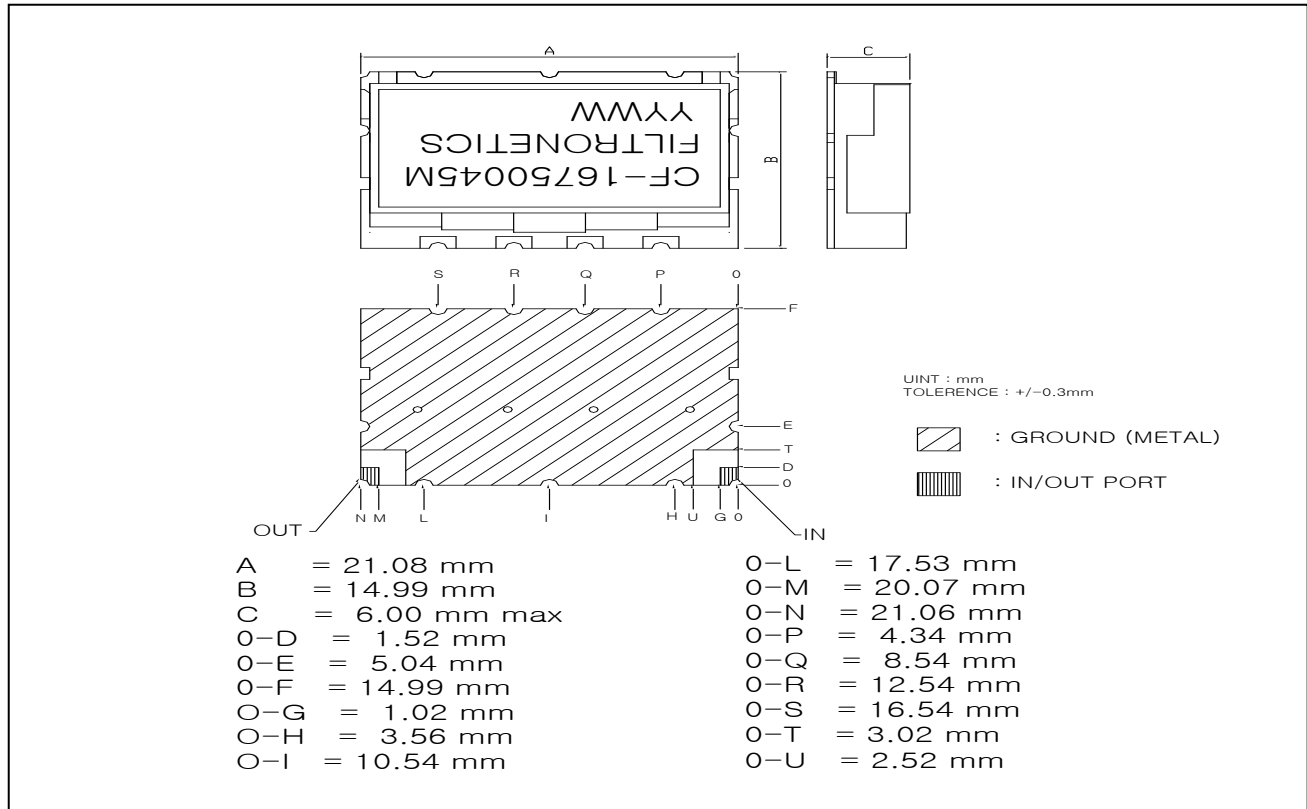

MATERIAL SPECIFICATION

1. PCB
 - 1) MATERIAL: FR4
 - 2) TERMINALS: Au PLATED
1. METAL CASE
 - 1) COVER MATERIAL: Brass (Sn OR Ni PLATED)
2. RESONATOR : Dielectric Resonator
 - 1) COATING MATERIAL: Ag
 - 2) Number of Poles :5 Poles

MARKING

Part No
 Filtronetics
 Data Code

UNIT: MM
 TOLERANCE: +/-0.3MM
 IN/OUT LAND : +/-0.3MM

● CAUTIONS:

1. When handling products, be careful not to damage the outer-electrode.
2. When handling products be careful not to touch the outer-electrode with bare hands or solder-ability is reduced.
3. Do not apply excessive pressure or shock to product in handling or in transportation or damage to the ceramic filters may result.

5. GRAPHS:

S21 vs S11 (INSERTION LOSS, RETURN LOSS, ATTENUATION, V.S.W.R, SMITH CHART)

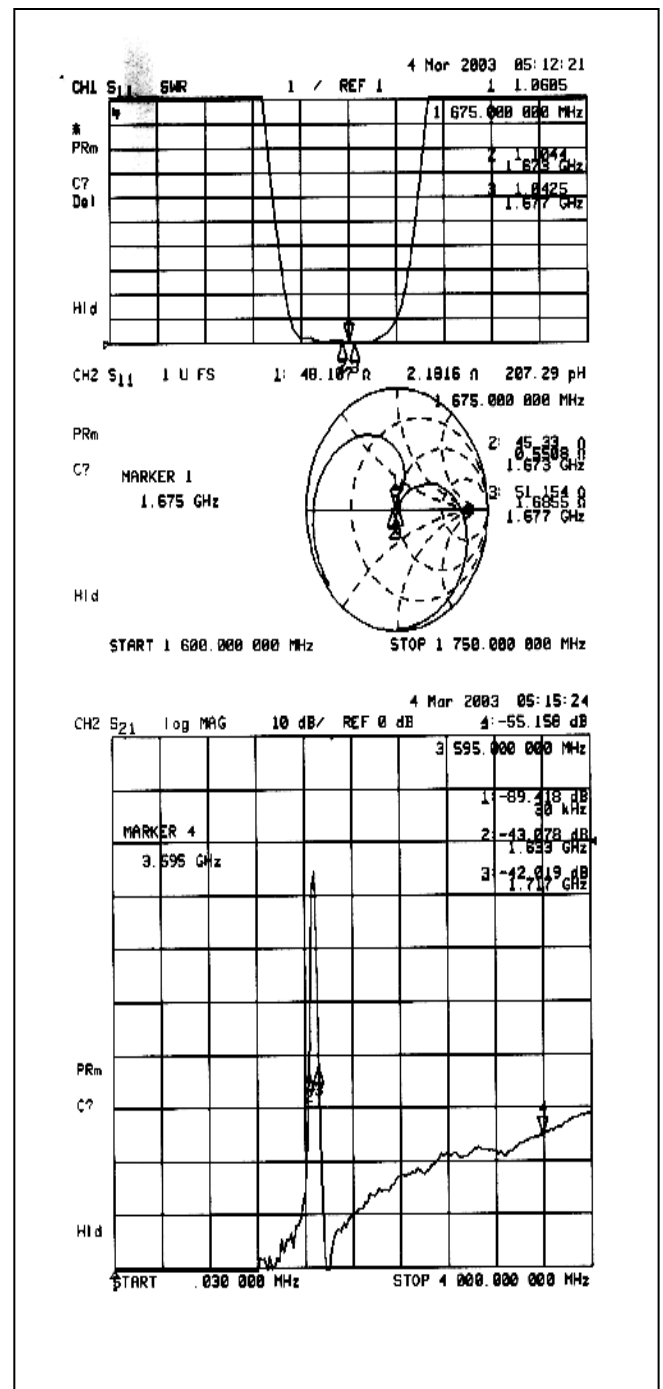
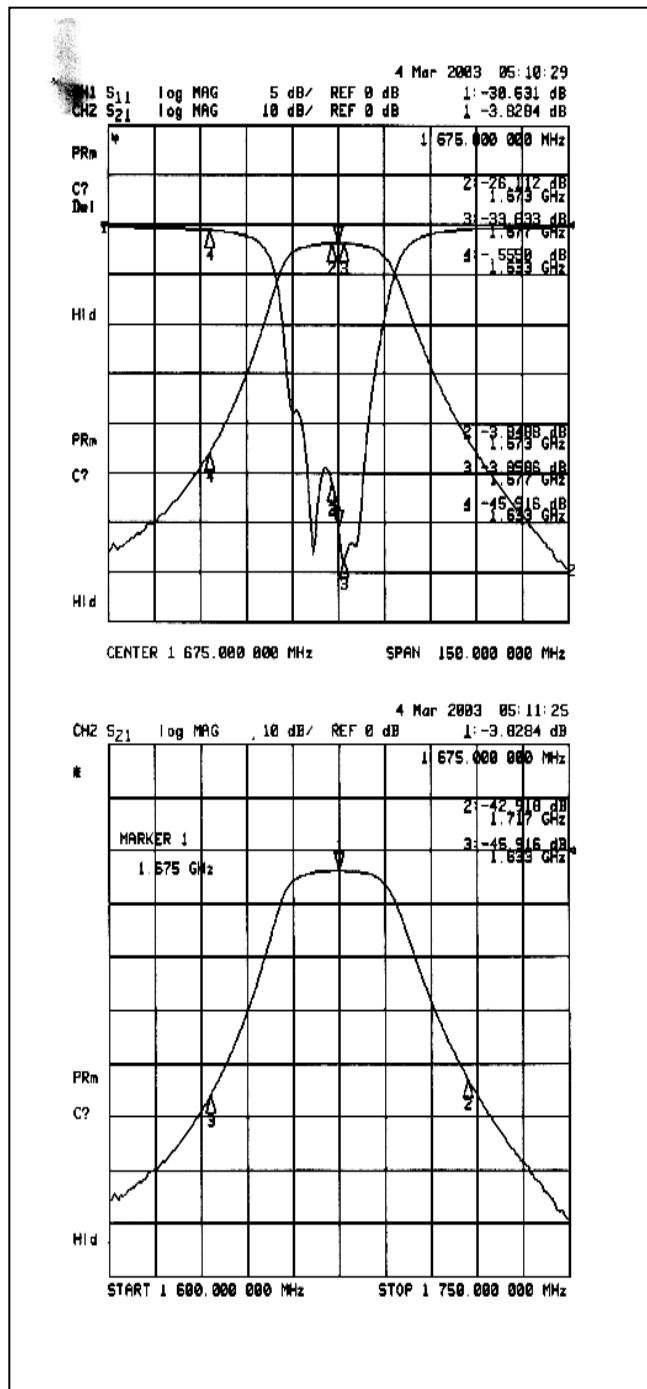

Recommended Land Pattern:

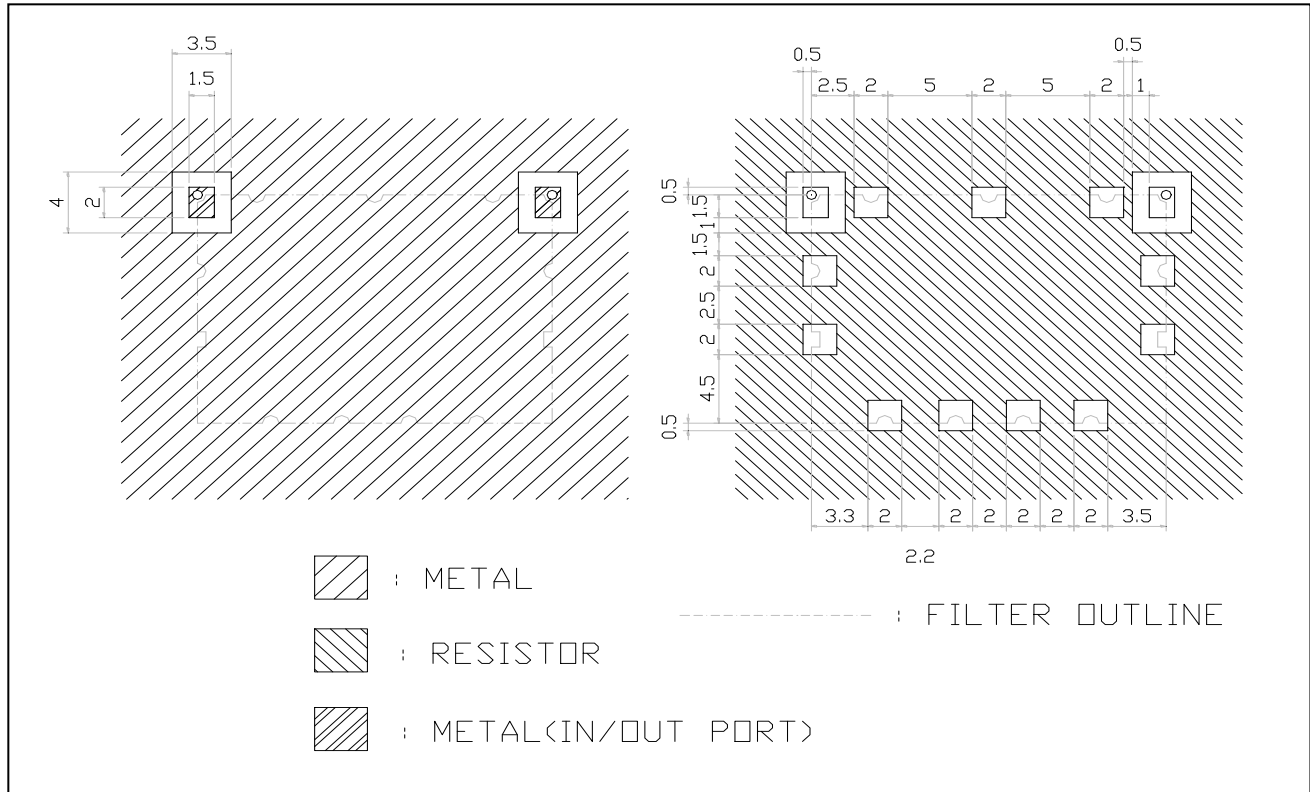

Note : Recommended Land Pattern (Thickness 1.0mm, Glass Epoxy, Dielectric Constant 4.8, copper plating on both surfaces)

6. DEFINITIONS

TERMS	DESCRIPTION	SPECIFICATION
Center Frequency	The midpoint of through band pass filter pass band, normally expressed as the arithmetic mean of the -3db point. Also called f_0 .	3. SPECIFICATION
Pass Band Width	The width of the pass band of a filter referenced to the minimum insertion loss point in the pass band. The pass band of a filter is stated as -1.0dB bandwidth.	
Insertion Loss	The loss of the filter, in db, measured at center frequency relative to a through line (0 dB).	
Attenuation	Reduction of RF power through a filter measured in dB, at desired band and referenced to 0 dB. (Filter to be removed from circuit)	
Pass Band Ripple	Variations in loss in the pass band of the filter, superimposed upon the fundamental shape of the pass band.	
V.S.W.R in Pass Band	The ratio of the maximum value of a standing wave to its minimum value, related to the return loss in pass band.	

8. REFLOW SOLDERING STANDARD CONDITIONS

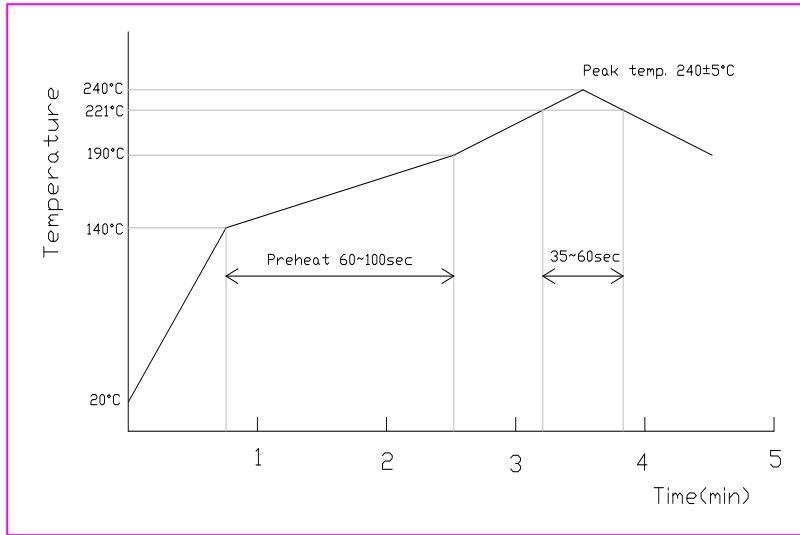

- Measuring point of temperature in-out terminals of the device.
- Reflow Soldering
- Both convection and infrared rays
- Hot air
- Solder Cream: Sn96.5/Ag3.5

9. PACKING TRAY DIMENSION:

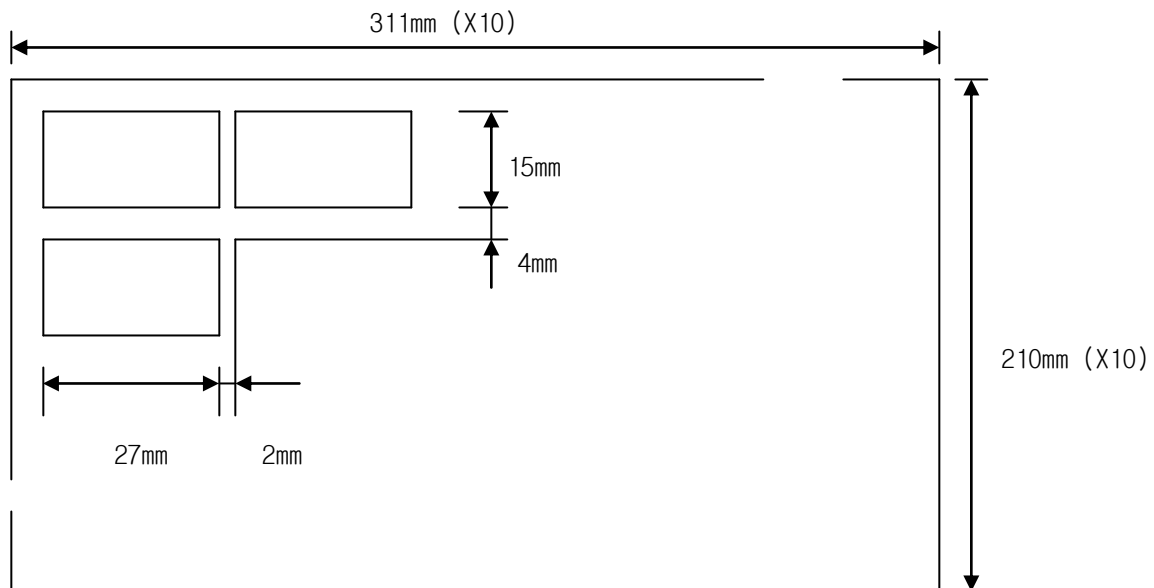

HEIGHT: 5.4mm

MATERIAL: ABS