

SPECIFICATION
COMMERCIALLY AVAILABLE

CERAMIC BAND PASS
PART NUMBER: CF-13801605A
RoHS

| ISSUED / REVISION | ENGINEER APPROVED | DOCUMENT CHECKED | DRAFTSMAN |
|---------------------------|-------------------|------------------|---------------|
| 3/25/2014 ^(kn) | 03/27/2014 TFG | | 03/27/2014 GL |
| | | | |
| | | | |
| | | | |

FILTRONETICS Inc

1. APPLICATION

THIS SPECIFICATION APPLIES TO BAND PASS FILTER, USING DIELECTRIC RESONATORS.

2. PART NUMBER

| | |
|-----------|--------------|
| PART NO | CF-13801605A |
| PACKAGING | PLASTIC TRAY |

3. SPECIFICATIONS

| NO | ITEMS | Ref. | SPECIFICATION |
|----|--------------------------------------|-------------|----------------|
| 1 | Center Frequency (Fo) | a1 | 1380 MHz |
| 2 | 3.0 dB Bandwidth | b1 | 160 MHz +/-10% |
| 3 | Insertion Loss At Fo | a1 | 3.0 dB Max |
| 4 | V.S.W.R AT Fo+/-64MHz | - | 1.75:1 Min |
| 5 | Attenuation [absolute value] | At 1220 MHz | 30 dB Min |
| | | At 1540 MHz | 25 dB Min |
| 6 | Group Delay Variation At Fo+/-64 MHz | - | 30 ns Max |
| 7 | Impedance | - | 50Ω |
| 8 | Maximum Input Power | - | 1 W (+30 dBm) |
| 9 | Operating Temperature Range | - | -35 ~ +85°C |

S21 LOG MAG NETWORK ANALYZER

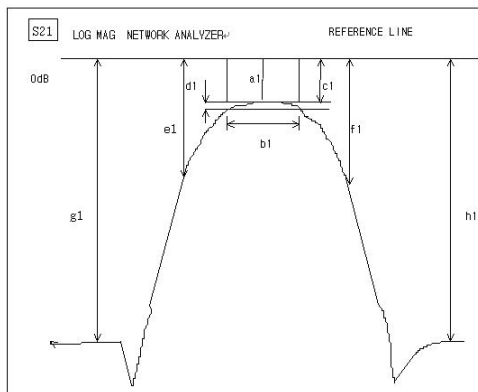

S11 LOG MAG NETWORK ANALYZER

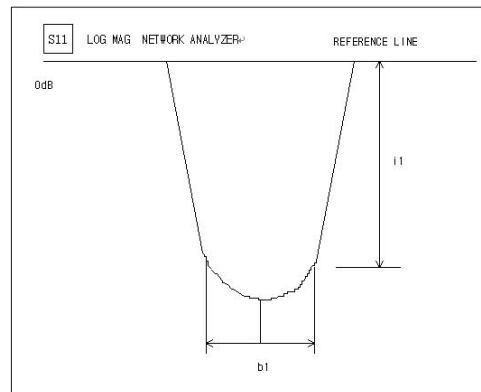

5. DIMENSIONS

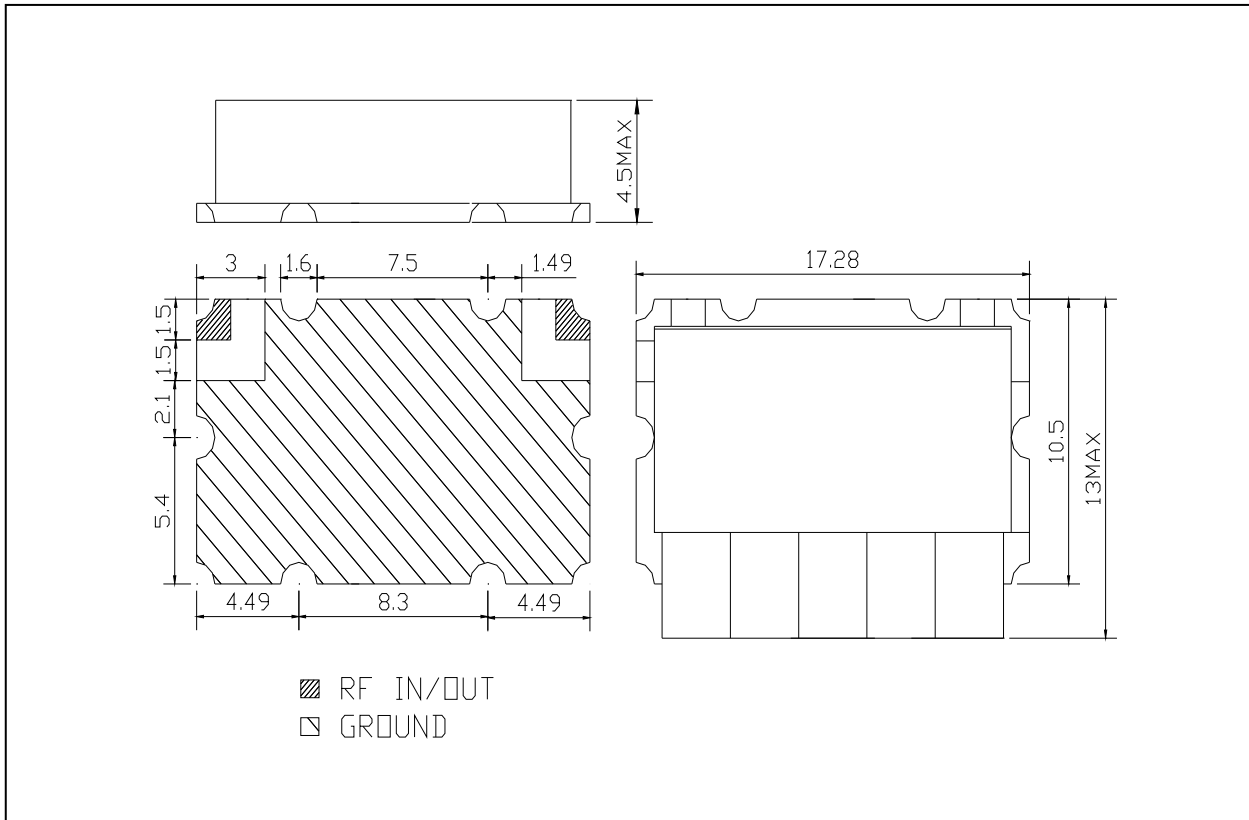

- MATERIAL SPECIFICATION**
1. PCB
 - 1) MATERIAL: FR4
 - 1) TERMINALS: Au Plated
 2. METAL CASE
 - 1) COVER MATERIAL: Brass (Sn OR Ni PLATED)
 3. RESONATOR : Dielectric Resonator
 - 1) COATING MATERIAL: Ag
 - 2) Number of Poles : 5 Poles
 4. RoHS Compliant

UNIT: MM
 TOLERANCE: +/-0.5MM
 IN/OUT LAND: +/-0.3MM

LABEL MARKING:
 CF-13801605A
 Date Code

● CAUTIONS:

1. When handling products, be careful not to damage the outer-electrode.
2. When handling this product be careful not to touch the outer-electrode with bare hands or solderability is reduced.
3. Do not apply excessive pressure or shock to product in handling or in transportation or damage to the ceramic filters may result.

5. GRAPHS

S21 vs S11 (INSERTION LOSS, RETURN LOSS, V.S.W.R, SMITH CHART)

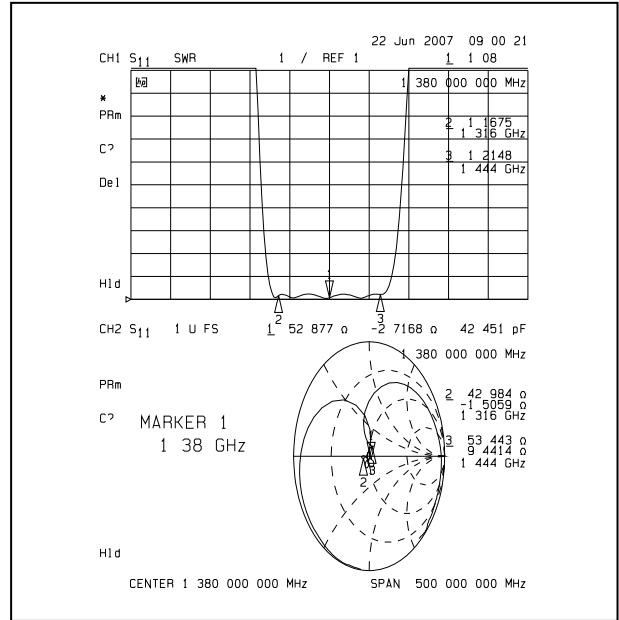
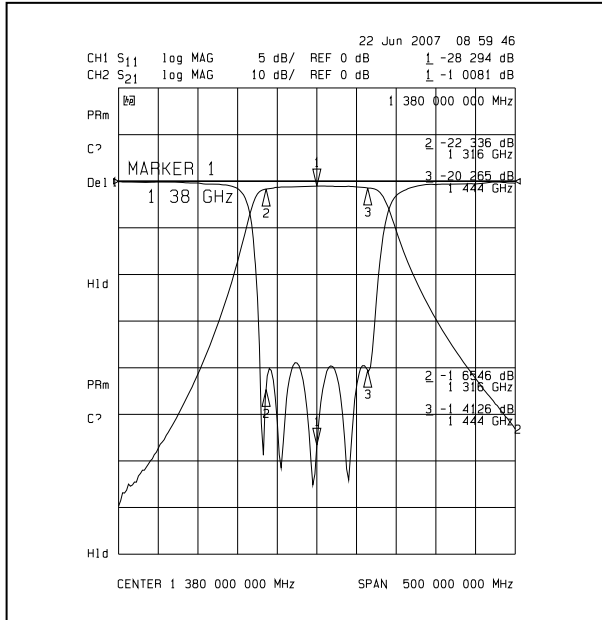

S21 (3dB BAND WIDTH, GROUP DELAY)

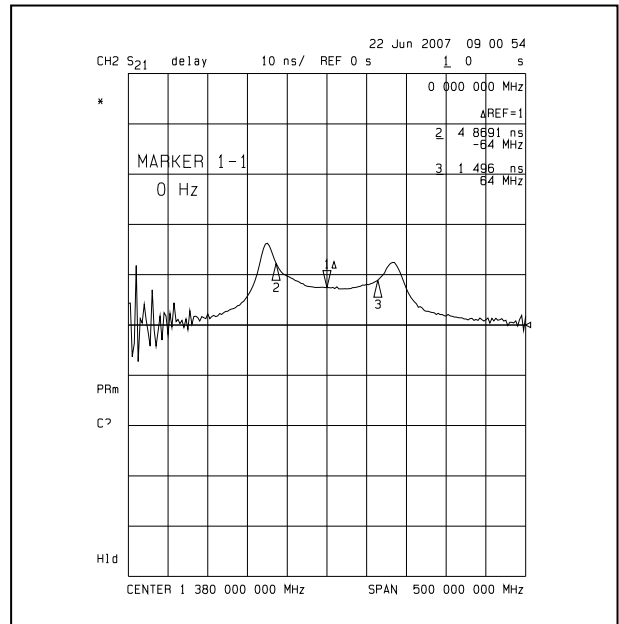
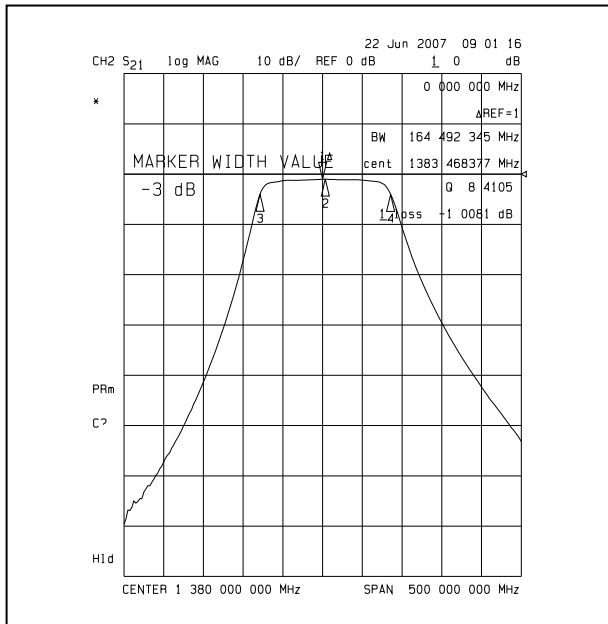

S21 (ATTENUATION, OUT BAND ATTENUATION)

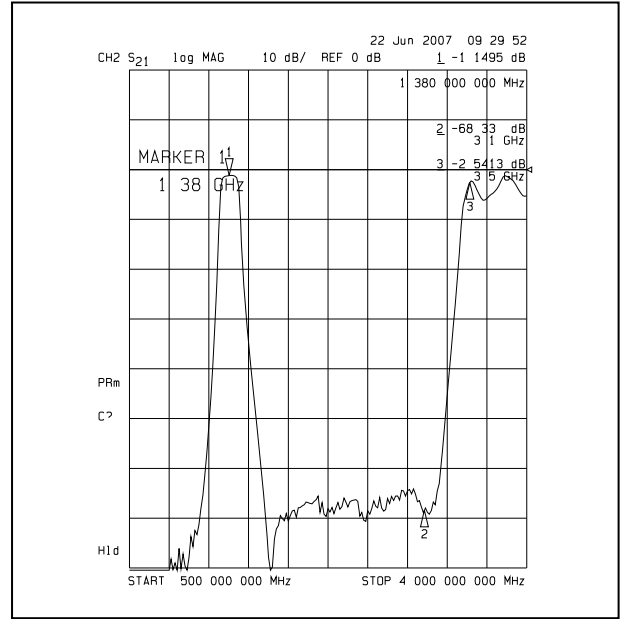
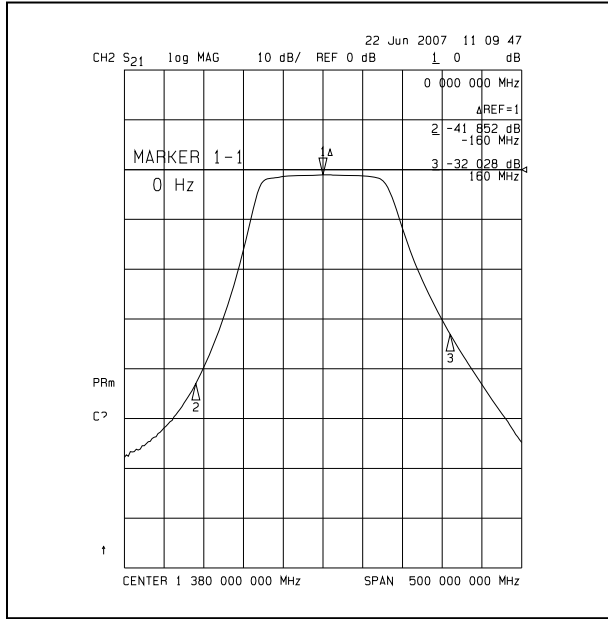

Recommended Solder Pattern:

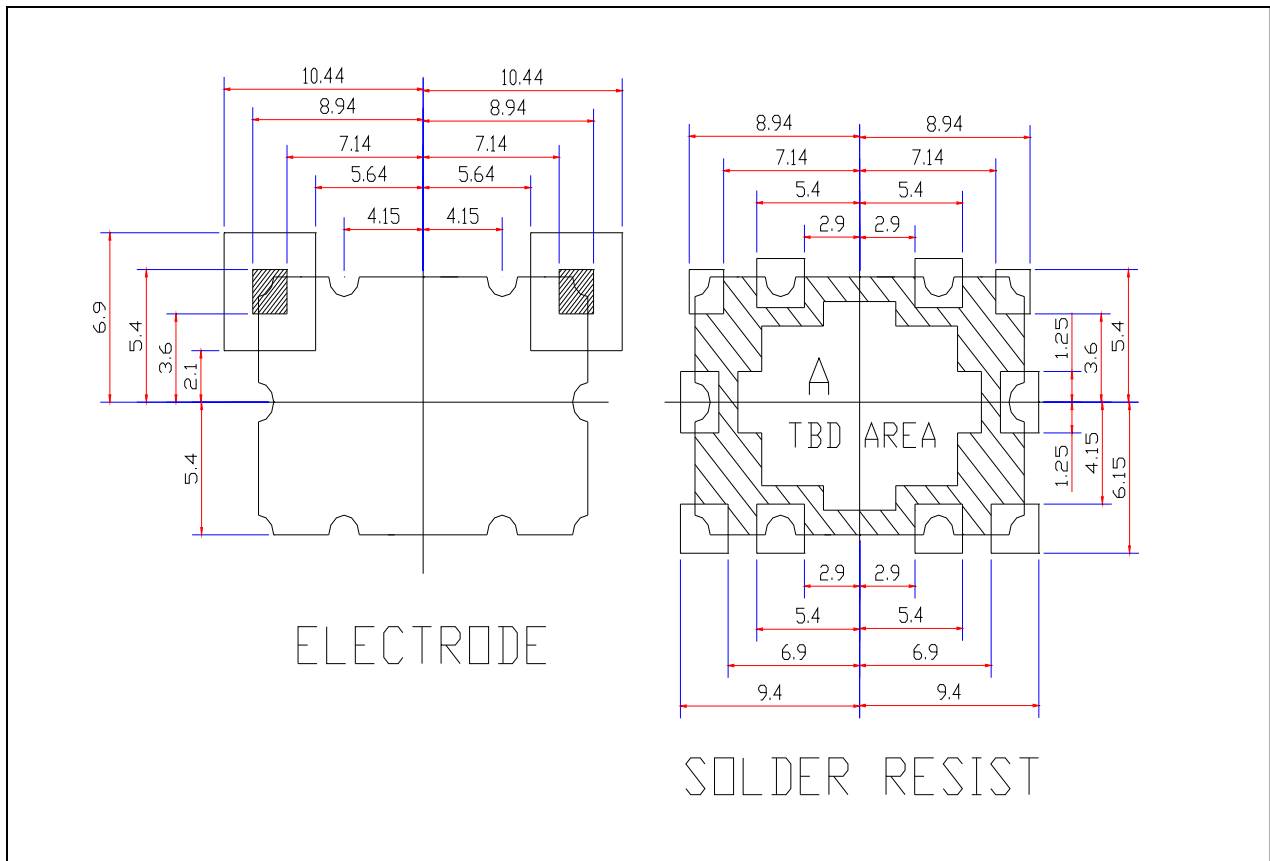

6. DEFINITIONS

| TERMS | DESCRIPTION | SPECIFICATION |
|----------------------|--|------------------|
| Center Frequency | The midpoint of through band pass filter pass band, normally expressed as the arithmetic mean of the -3dB point. Also called Fo. | 3. SPECIFICATION |
| Pass Band Width | The width of the pass band of a filter referenced to the minimum insertion loss point in the pass band. The pass band of a filter is stated as -1.0dB bandwidth. | |
| Insertion Loss | The loss of the filter, in dB, measured at center frequency relative to a through line (0 dB). | |
| Attenuation | Reduction of RF power through a filter measured in dB, at desired band and referenced to 0 dB. (Filter to be removed from circuit) | |
| Pass Band Ripple | Variations in loss in the pass band of the filter, superimposed upon the fundamental shape of the pass band. | |
| V.S.W.R in Pass Band | The ratio of the maximum value of a standing wave to its minimum value, related to the return loss in pass band. | |

7. RELIABILITY TEST AND CONDITIONS:

| ITEM | TEST CONDITIONS | REQUIREMENTS |
|---|--|--|
| Resistance to solder heat | Preheat temperature : 120 to 150°C Preheat time: 1 to 1.5 min Solder temperature: 260 +/- 10°C Dipping time: 10 +/- 0.5 sec | No damage such as cracks should be caused in chip element. |
| Solderability | Preheat temperature: 120 to 150°C Preheat time: 1 to 1.5 min Solder temperature: 235 +/- 5°C Dipping time: 5 +/- 1 sec | More than 80% of the terminal electrode shall be covered with new solder |
| Heat resistance (High-temperature Load) | Temperature: 85 +/- 2°C Applied voltage: Rated voltage Applied current: Rated current Recovery: 1 to 2hrs of recovery under the standard condition after the removal from test chamber. | No mechanical damage. After test, the device shall satisfy the specification in section 3. |
| Thermal shock (Temperature cycle) | Conditions for 1 cycle Step 1: + 85°C 15 min Step 2 : - 30°C 15 min Number of cycle: 10 | No mechanical damage. After test, the device shall satisfy the specification in section 3. |
| Vibration | Frequency: 10 ~ 50 Hz Amplitude: 1.52mm (0.060 inches) Direction: X, Y and Z Time: each 30 min for all directions | No mechanical damage. After test, the device shall satisfy the specification in section 3. |

8. REFLOW SOLDERING STANDARD CONDITIONS FOR RoHS

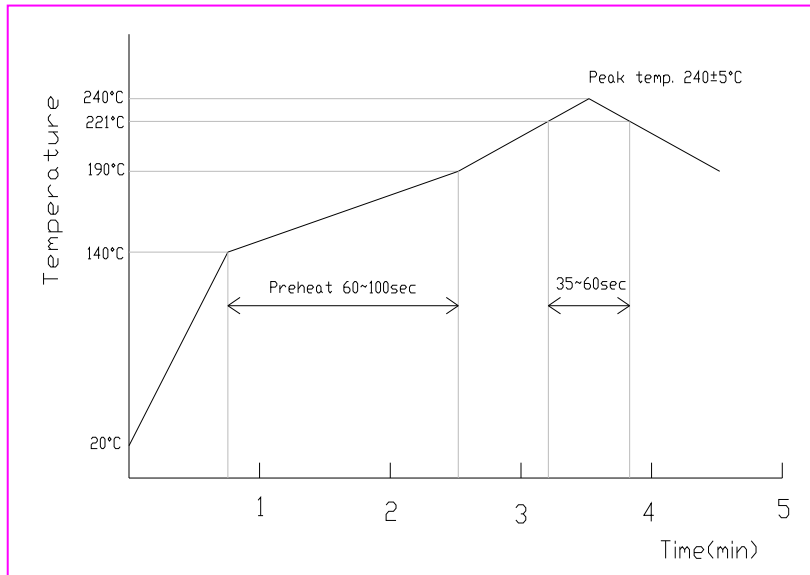

- Measuring point of temperature in-out terminals of the device.
- Reflow Soldering
- Both convection and infrared rays
- Hot air
- Hot plates
- Solder Cream: Sn96.5/Ag3.5