

**SPECIFICATION**  
**COMMERCIALY AVAILABLE**

**DIELECTRIC CERAMIC FILTER**  
**PART NUMBER CF-12800085**

ISSUED	CHECKED	CHECKED	CHECKED
10/22/09 DS	5/16/2011 SRJ	5/18/2011 BF	5/18/2011 GL

***FILTRONETICS Inc***

1. APPLICATION

THIS SPECIFICATION APPLIES TO A BAND PASS FILTER, USING DIELECTRIC RESONATORS

2. PART NUMBER:

PART NO	CF-12800085
PACKAGING	PLASTIC TRAY

3. SPECIFICATIONS:

NO	ITEMS	Ref.	SPECIFICATION
1	Center Frequency (Fo)	-	1280 MHz
2	Pass Band Width (PB)	-	Fo +/-4 MHz
3	Insertion Loss At Fo	-	5.0 dB Max
4	Attenuation [Absolute Value]	Fo -70 MHz	65 dB Min
		Fo +70 MHz	63 dB Min
5	70 dB Band Width		160 MHz Max
6	Ripple IN PB		0.5 dB Max
7	V.S.W.R IN PB	-	1.75:1 Max
8	Impedance	-	50Ω
9	Maximum Input Power	-	1 W (+30 dBm)
10	Operating Temperature Range	-	-20 ~ +80 °C

S21 LOG MAG NETWORK ANALYZER

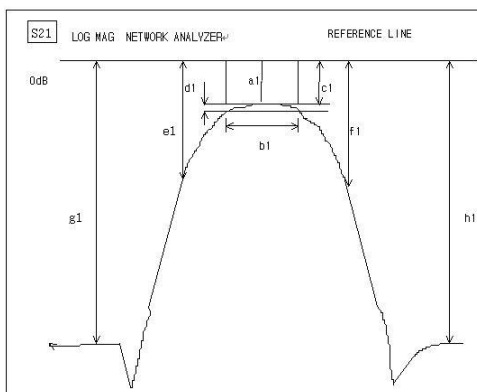

S11 LOG MAG NETWORK ANALYZER

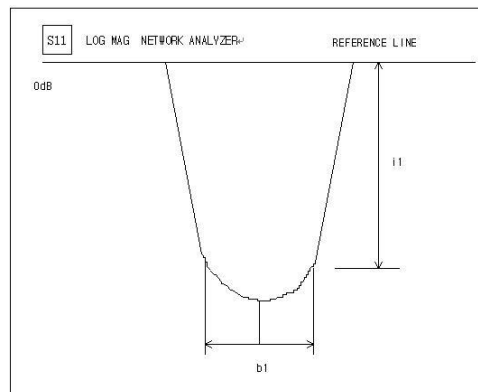

4. DIMENSIONS:

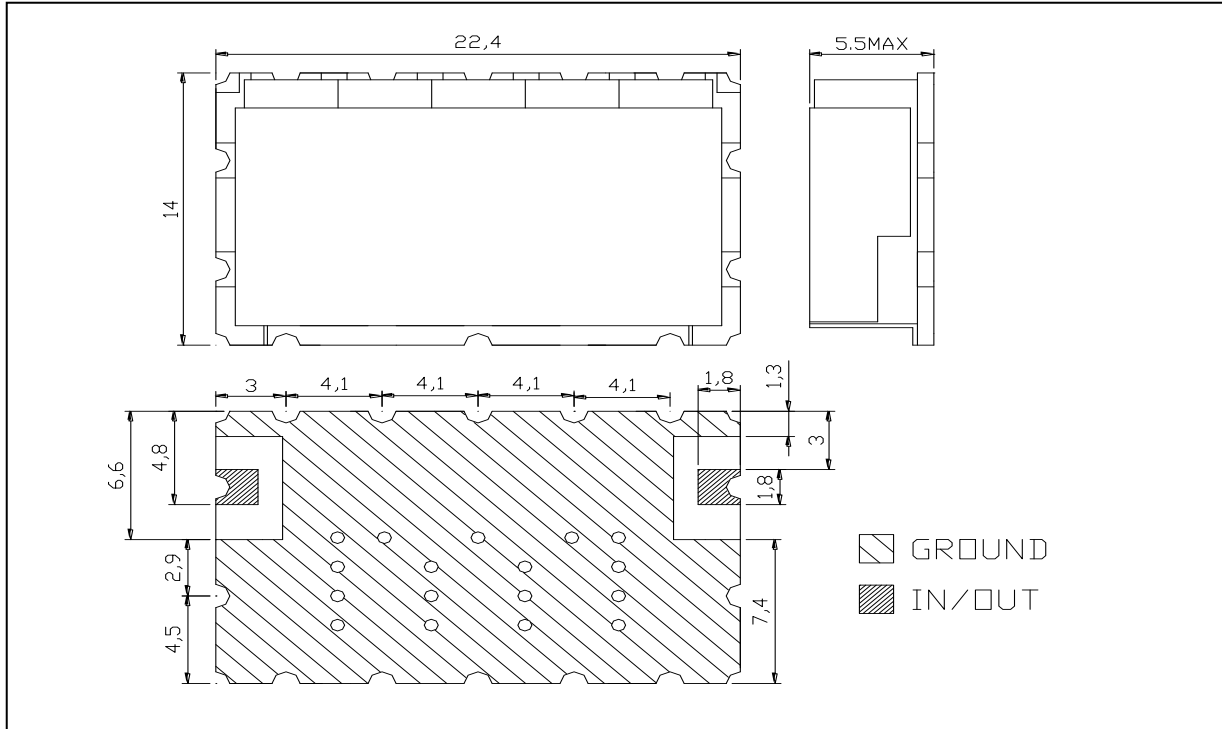

MATERIAL SPECIFICATION

2. PCB
  - 1) MATERIAL: FR4
  - 2) TERMINALS: Au PLATED
3. METAL CASE
  - 1) MATERIAL: Sn OR Ni PLATED
4. RESONATOR
  - 1) COATING MATERIAL: Ag

MARKING

Part No CF-12800085  
 Filtronetics, Inc  
 Date Code

UNIT: MM  
 TOLERANCE: +/-0.5MM  
 IN/OUT LAND: +/-0.3MM

● CAUTIONS:

1. When handling products, be careful not to damage the outer-electrode.
2. When handling products, be careful not to touch the outer-electrode with bare hands or solderability is reduced.
3. Do not apply excessive pressure or shock to product in handling or in transportation or damage to the ceramic filters may result.

5. GRAPHS:

S21 & S11 (INSERTION LOSS, RETURN LOSS, V.S.W.R, SMITH CHART)

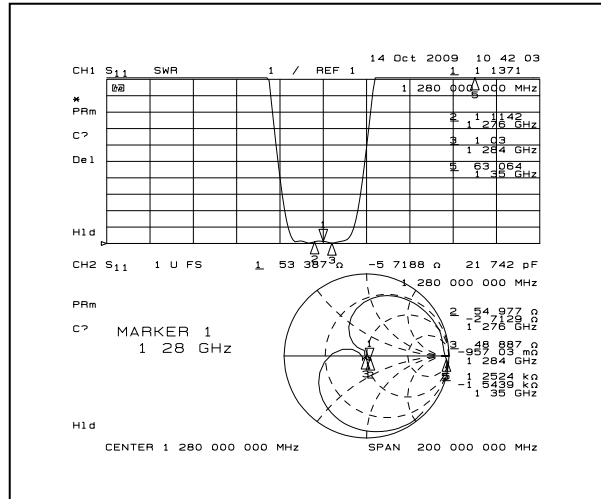
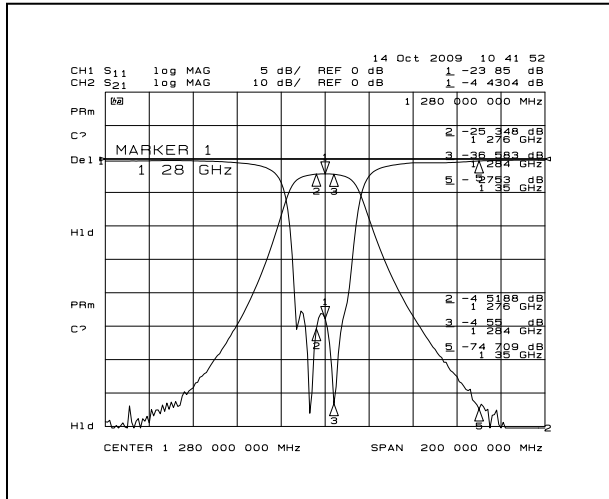

S21 (1dB, 70dB BAND WIDTH)

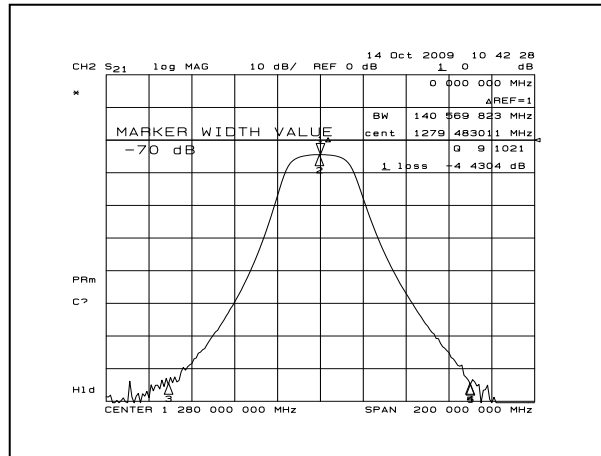
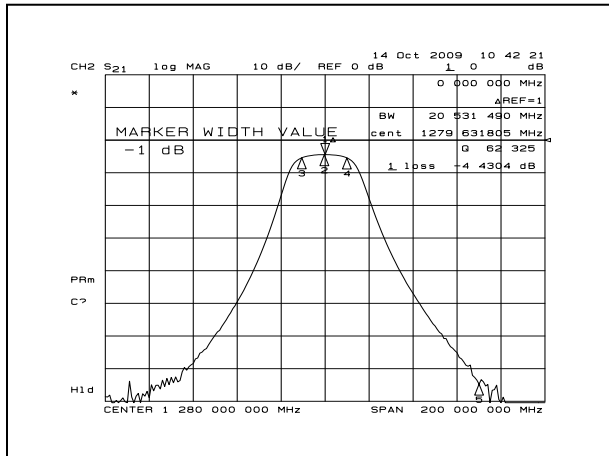

S21 (ATTENUATION)

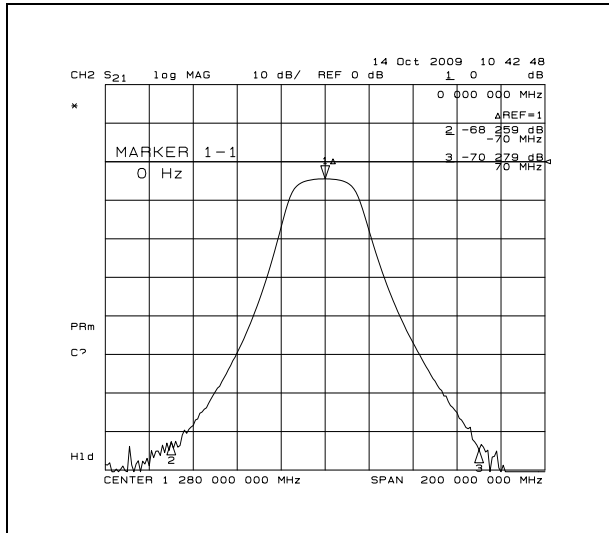

6. DEFINITIONS:

	DESCRIPTION	SPECIFICATION
Center Frequency	The midpoint of through band pass filter pass band, normally expressed as the arithmetic mean of the -3dB point. Also called Fo.	3. SPECIFICATION
Pass Band Width	The width of the pass band of a filter referenced to the minimum insertion loss point in the pass band. The pass band of a filter is stated as -1.0dB bandwidth.	
Insertion Loss	The loss of the filter, in dB, measured at center frequency relative to a through line (0 dB).	
Attenuation	Reduction of RF power through a filter measured in dB, at desired band and referenced to 0 dB. (Filter to be removed from circuit)	
Pass Band Ripple	Variations in loss in the pass band of the filter, superimposed upon the fundamental shape of the pass band.	
V.S.W.R in Pass Band	The ratio of the maximum value of a standing wave to its minimum value, related to the return loss in pass band.	