

# SPECIFICATION

COMMERCIALY AVAILABLE

ITEM: DIELECTRIC CERAMIC FILTER  
PART NUMBER: CF-11801405

Added Graphs 10/24/13

ISSUED	CHECKED	CHECKED	CHECKED	APPROVED
8/27/07xx				
10/24/13 PM		10/25/2013 GL		10/25/2013 TFG

**FILTRONETICS Inc**

1. APPLICATION

THIS SPECIFICATION APPLIES TO BAND PASS FILTER USING DIELECTRIC RESONATORS.

2. PART NUMBER

PART NO	CF-11801405
PACKAGING	PLASTIC TRAY

3. SPECIFICATIONS

NO	ITEMS	Ref.	SPECIFICATION
1	Center Frequency (Fo)	a1	1180 MHz
2	3.0dB Band Width	b1	140 MHz +/-10%
3	Insertion Loss AT Fo	a1	3.0 dB Max
4	V.S.W.R AT Fo+/-56MHz	-	1.75:1 Min
5	Attenuation [absolute value]	At 1040 MHz	30 dB Min
		At 1320 MHz	25 dB Min
6	Group Delay Variation AT Fo+/-56MHz	-	30ns Max
7	Impedance	-	50Ω
8	Maximum Input Power	-	1 W (+30dBm)
9	Operating Temperature Range	-	-35 ~ +85°C
10	Workmanship	-	IPC-610 class 3
11	Process Temperature	-	+150°C for 1 hour or +230°C for 10 minutes

S21 LOG MAG NETWORK ANALYZER

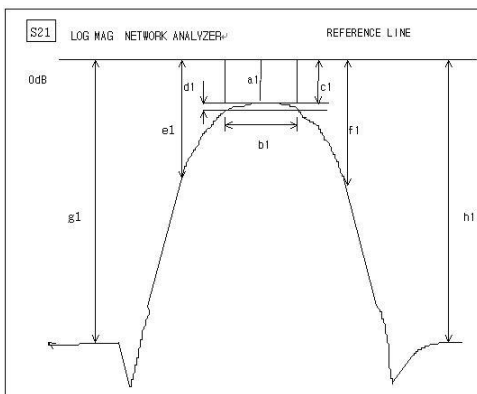

S11 LOG MAG NETWORK ANALYZER

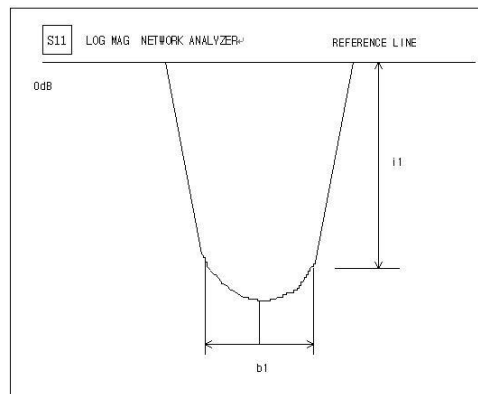

## 4. DIMENSIONS

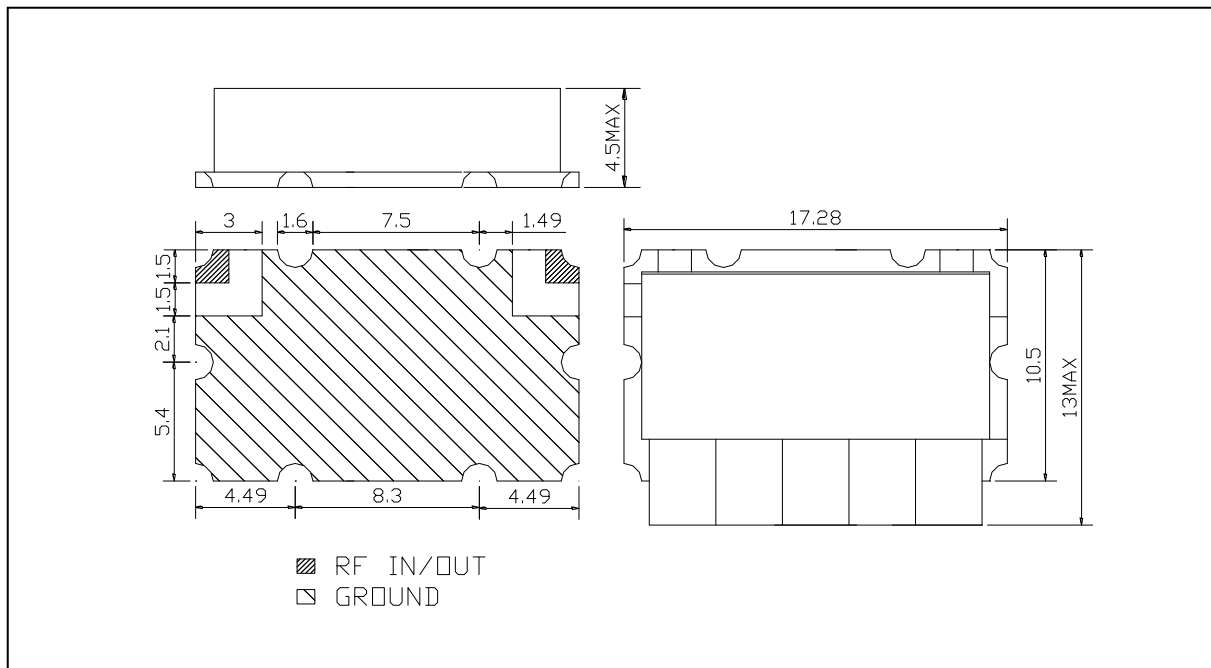

## ※ MATERIAL SPECIFICATION

2. PCB
  - 1) MATERIAL: FR4
  - 2) TERMINALS: Sn/Pb, HASL
3. METAL CASE
  - 1) Ag or Sn or Ni plated brass
4. RESONATOR
  - 1) COATING MATERIAL: silver plate, 8~30um
5. INTERNAL SOLDER
  - 1) Sn96.5/Ag3.5 Lead Free solder,  
221 deg C melting
6. RESONATORS TABS
  - 1) Sn/Pb(9:1) Plated or Ag brass
7. NO PURE TIN ALLOWED

## ※ MARKING

Label Material: High temp polyimide

Marking:

**CF-11801405**

Filtronetics

Date Code

## CAUTIONS:

1. When handling products, be careful not to damage the outer-electrode.
2. When handling products be careful not to touch the outer-electrode with bare hands or solder-ability is reduced.
3. Do not apply excessive pressure or shock to product in handling or in transportation or damage to the ceramic filters may result.

5. GRAPHS

S21 vs S11 (INSERTION LOSS, RETURN LOSS, V.S.W.R, SMITH CHART)

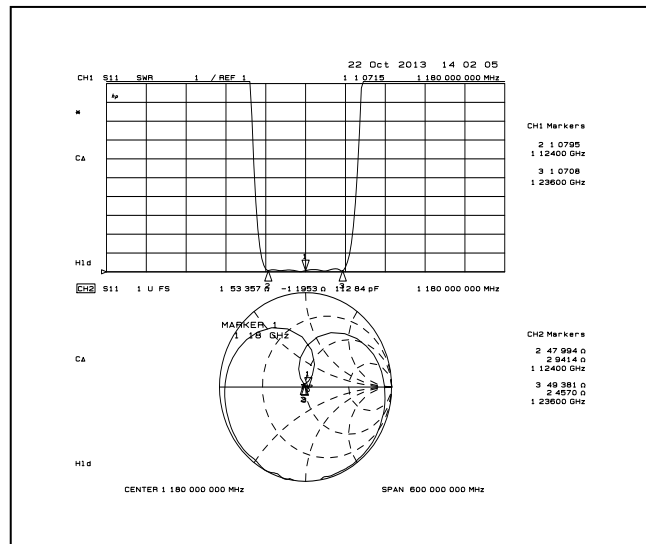
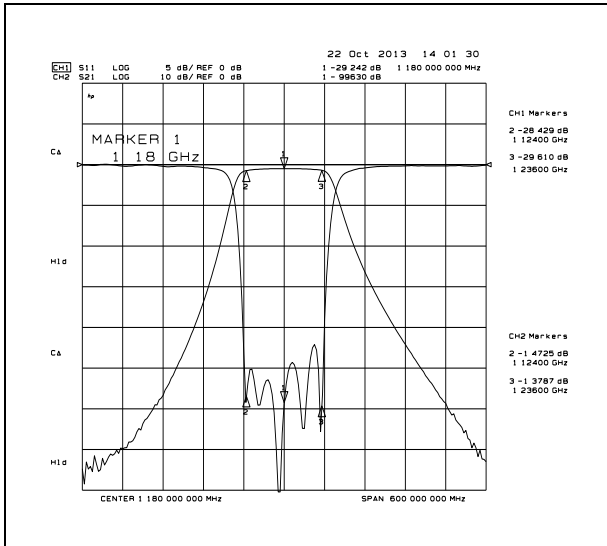

S21( Group Delay, 3DB BAND WIDTH)

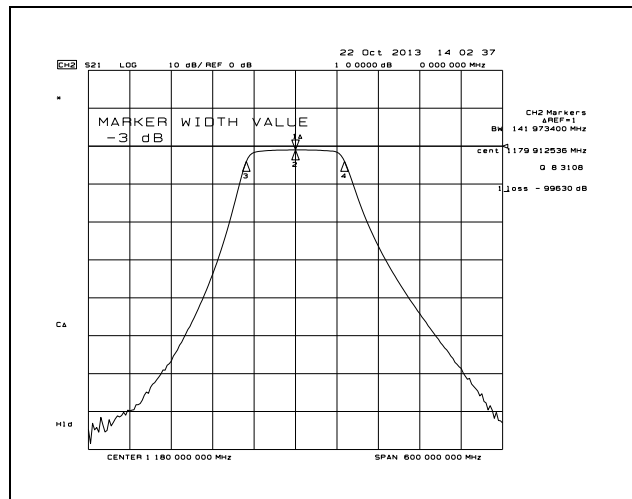
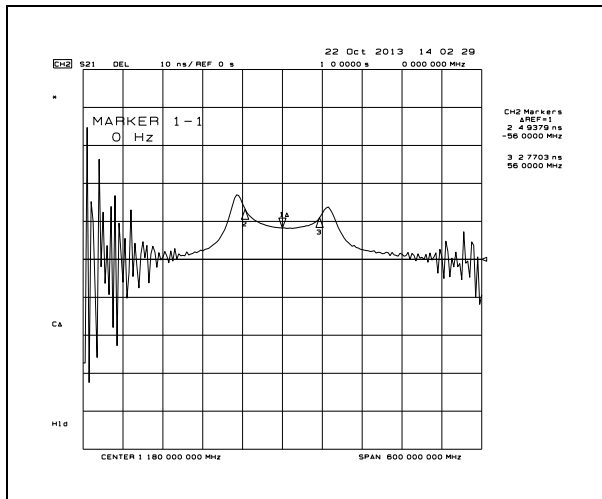

S21( Attenuation, Out Band Attenuation)

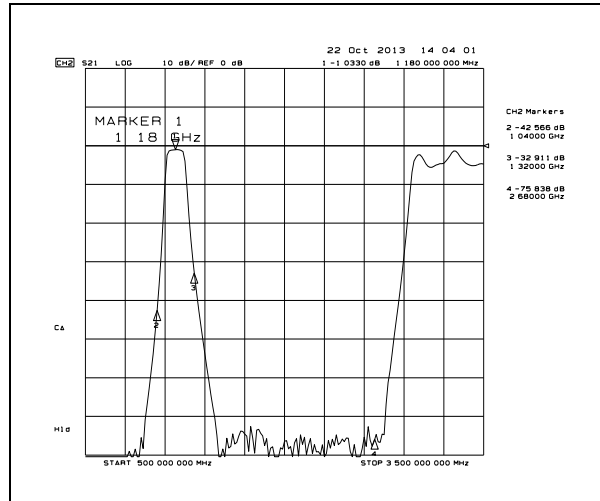
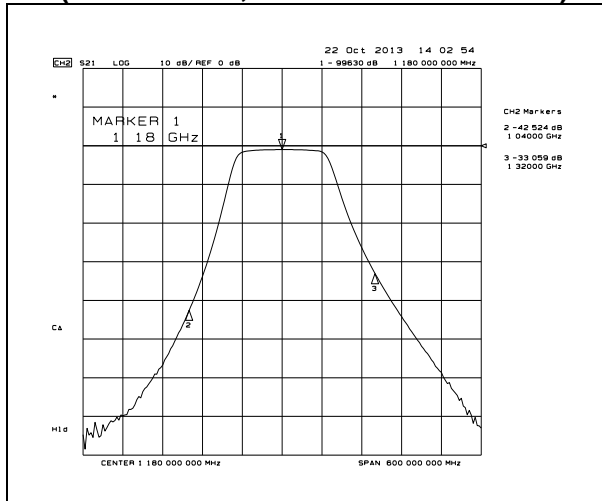

Recommended Solder Pattern:

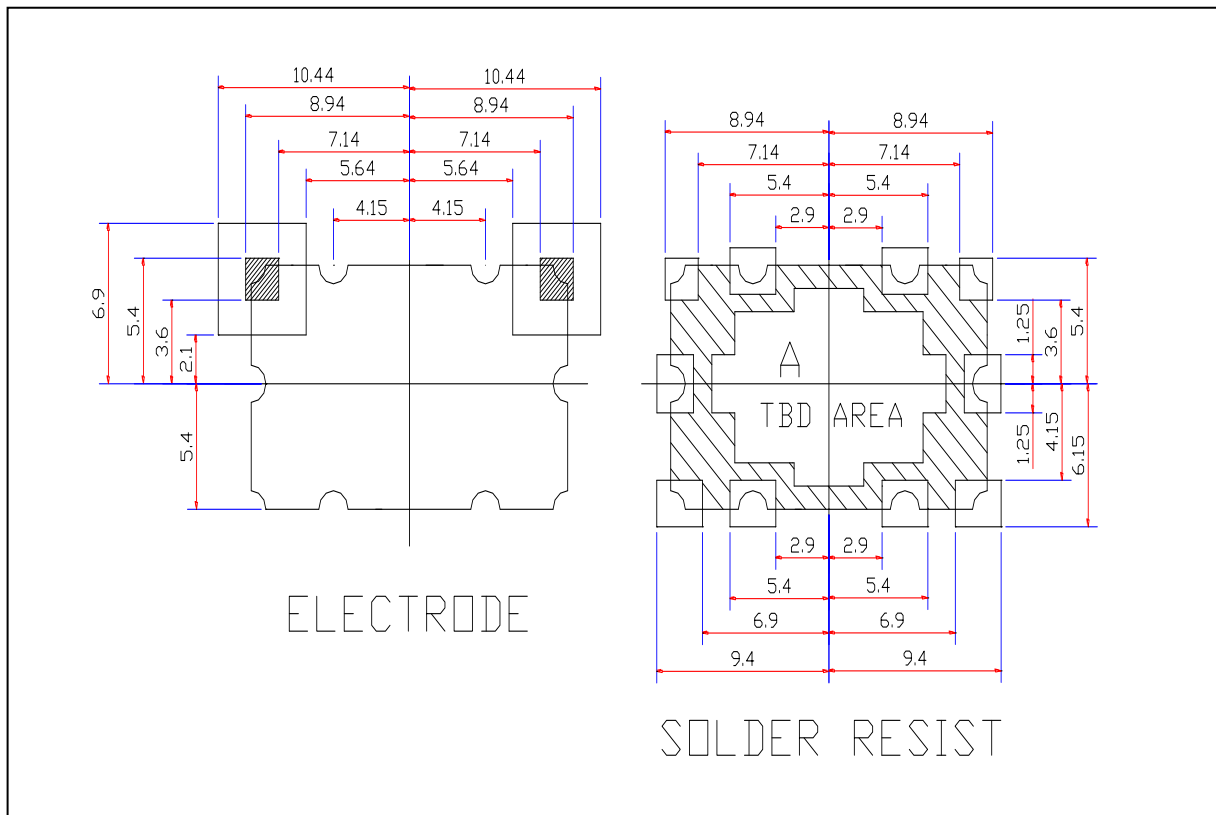

<p align="center"><b>Quality Conformance Test 100% Final inspection</b>  <b>100% Test Data</b></p>	
1)	Visual mechanical to IPC-610 Class 3 Including inspection for cleanliness.
2)	Thermal Shock -44 to +85°C 10 cycles
3)	Electrical Specifications at ambient

6. DEFINITIONS

TERMS	DESCRIPTION	SPECIFICATION
Center Frequency	The midpoint of through band pass filter pass band, normally expressed as the arithmetic mean of the -3db point. Also called fo.	3. SPECIFICATION
Pass Band Width	The width of the pass band of a filter referenced to the minimum insertion loss point in the pass band. The pass band of a filter is stated as -3.0dB bandwidth.	
Insertion Loss	The loss of the filter, in db, measured at center frequency relative to a through line (0 dB).	
Attenuation	Reduction of RF power through a filter measured in dB, at desired band and referenced to 0 dB. (Filter to be removed from circuit)	
Pass Band Ripple	Variations in loss in the pass band of the filter, superimposed upon the fundamental shape of the pass band.	
V.S.W.R in Pass Band	The ratio of the maximum value of a standing wave to its minimum value, related to the return loss in pass band.	

7. REFLOW SOLDERING STANDARD CONDITIONS

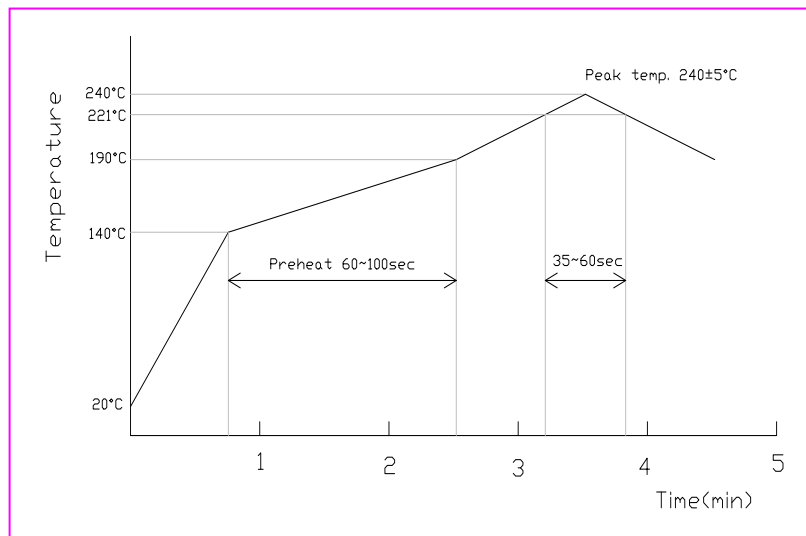

- Measuring point of temperature in-out terminals of the device.
- Reflow Soldering
- Both convection and infrared rays
- Hot air
- Solder Cream: Sn96.5/Ag3.5

## 8. RELIABILITY TEST AND CONDITIONS

ITEM	TEST CONDITIONS	REQUIREMENTS
Resistance to solder heat	Preheat temperature : 120 to 150°C Preheat time: 1 to 1.5 min Solder temperature: 260 +/- 10°C Dipping time: 10 +/- 0.5 sec <b>→Soldering Time : 5sec.max.per each terminal</b>	No damage such as cracks should be caused in chip element.
Solderability	Preheat temperature: 120 to 150°C Preheat time: 1 to 1.5 min Solder temperature: 235 +/- 5°C Dipping time: 5 +/- 1 sec	More than 80% of the terminal electrode shall be covered with new solder
Heat resistance (High-temperature Load)	Temperature: 85 +/- 2°C Applied voltage: Rated voltage Applied current: Rated current Recovery: 1 to 2hrs of recovery under the standard condition after the removal from test chamber.	No mechanical damage. After test, the device shall satisfy the specification in section 3. <b>Standard condition is 25+/-5°C and Less than 65% relative humidity</b>
Thermal shock (Temperature cycle)	Conditions for 1 cycle Step 1: + 85°C 15 min Step 2 : - 44°C 15 min Number of cycle: 10	No mechanical damage. After test, the device shall satisfy the specification in section 3.
Humidity Resistance	Temperature: 40 +/- 2°C Humidity: 90 to 95% RH Duration: 96 +/- 5 hrs Recovery: 1 to 2hrs of recovery under the standard condition after the removal from test chamber.	No mechanical damage. After test, the device shall satisfy the specification in section 3.
Vibration	The device is subjected to vibration of 2 sweeps in each of three mutually perpendicular planes Frequency shall be varied within 10~50Hz with 1.5mm double amplitude and within 50~500 Hz With 10G's acceleration. Sweep time of Frequency Shall be 15minutes	No mechanical damage. After test, the device shall satisfy the specification in section 3.
Shock	The device is subjected to 3 shocks in each direction of six mutually perpendicular planes Each shock shall be a half-sine wave shaped with a magnitude of 30G's and a duration of 11msec.	No mechanical damage. After test, the device shall satisfy the specification in section 3.