

SPECIFICATION

COMMERCIALY AVAILABLE

**ITEM: DIELECTRIC CERAMIC FILTER
PART NUMBER CF-09150262A**

Revision Made:

ISSUED / REVISION	ENGINEER APPROVED	DOCUMENT CHECKED	DRAFTSMAN	DOCUMENT CHECKED
3/12/2010 DS	3/12/2010 SRJ	3/15/2010 BF		

1. APPLICATION

THIS SPECIFICATION APPLIES TO A BAND PASS FILTER USING DIELECTRIC RESONATORS

2. PART NUMBER:

PART NO	CF-09150262A
PACKAGING	PLASTIC TRAY

3. SPECIFICATIONS:

NO	ITEMS	Ref.	SPECIFICATION
1	Center Frequency (Fo)	a1	915 MHz
2	Pass Band Width (=PB)	b1	Fo+/-13 MHz
3	Insertion Loss at Fo	-	2.5 dB max
4	Ripple IN PB	-	0.8 dB max
5	Return Loss IN PB	-	10 dB Min
6	18dB Band Width		160MHz Max
7	Attenuation	At Fo+80MHz	- 18MHz Min
	[Absolute Value]	At Fo-80MHz	- 15MHz Min
8	Impedance	-	50 Ω
9	Maximum Input Power	-	1 W (+30dBm)
10	Operating Temperature Range	-	-35 - +75 °C

S21 LOG MAG NETWORK ANALYZER

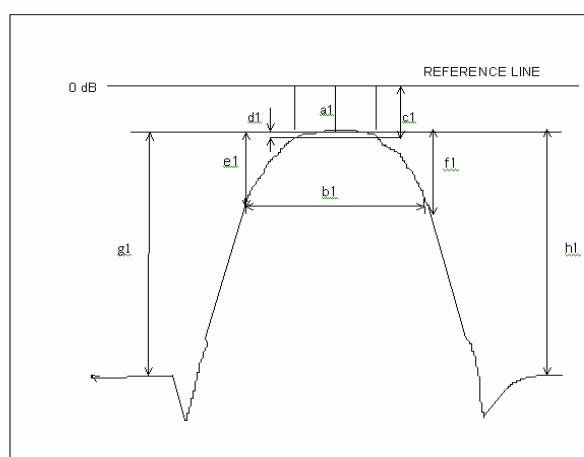

S11 SWR NETWORK ANALYZER

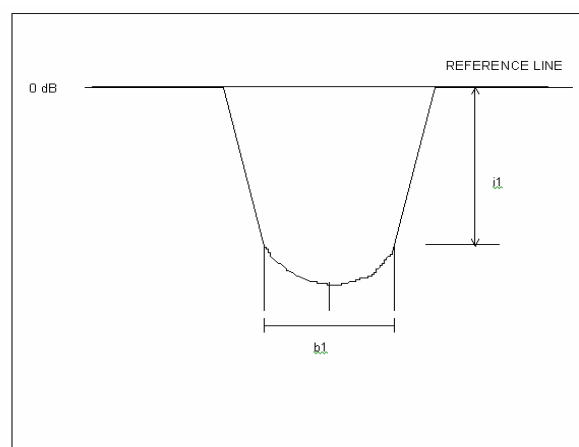

4. DIMENSIONS:

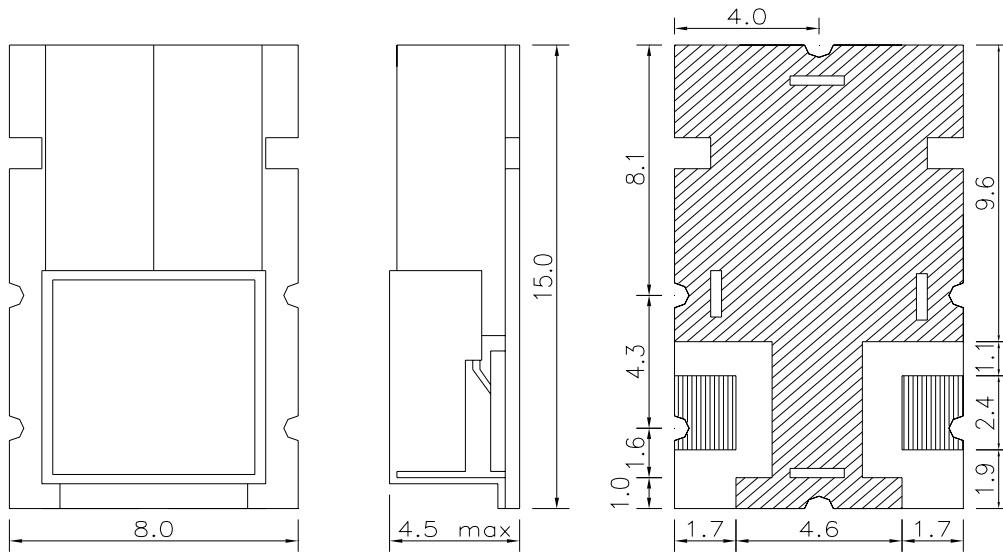

 : CONDUCTIVE METAL(GROUND)

 : CONDUCTIVE METAL(IN/OUT)

※ MATERIAL SPECIFICATION

1. PCB
 - 1) MATERIAL: FR4
 - 2) TERMINALS: Au PLATED
2. METAL CASE
 - 1) MATERIAL: Sn OR Ni PLATED
3. RESONATOR
 - 1) COATING MATERIAL: Ag
 - 2) DIMENSION: 3.0MM x 3.0MM

※ Marking

Part No CF-09150262A
 Filtronetics, Inc.
 YY/MM

UNIT: mm
 TOLERANCE: +/-0.5mm
 N/OUT LAND: +/-0.3mm

● CAUTIONS:

1. When handling products, be careful not to damage the outer-electrode.
2. When handling products be careful not to touch the outer-electrode with bare hands or solderability is reduced.
3. Do not apply excessive pressure or shock to product in handling or in transportation or damage to the ceramic filters may result.

4. GRAPHS:

S21 & S11 (INSERTION LOSS, RETURN LOSS, 3dB BAND WIDTH)

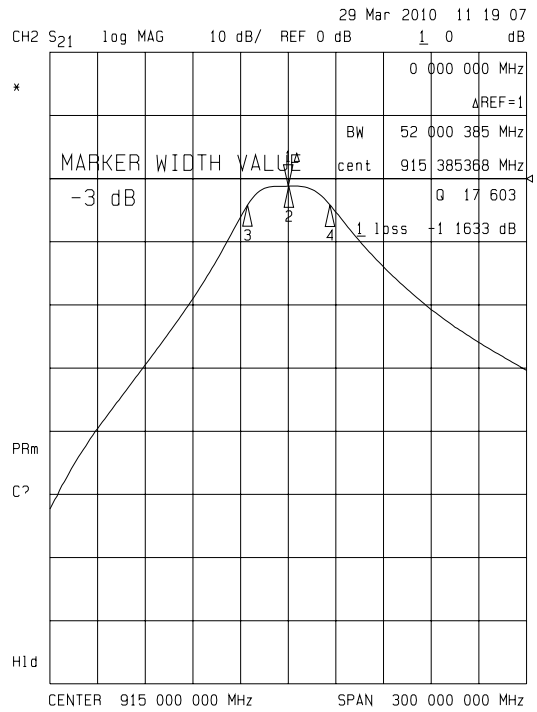
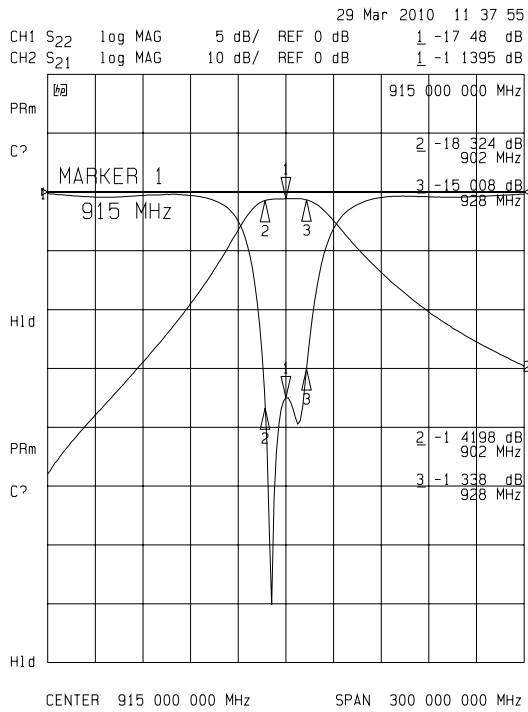

S21(18dB BAND WIDTH, ATTENUATION)

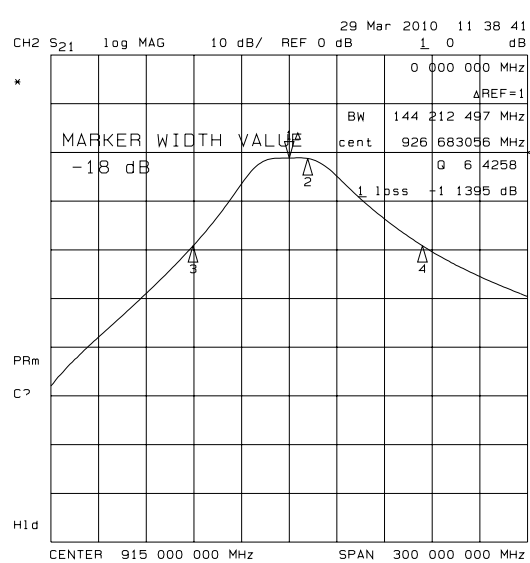
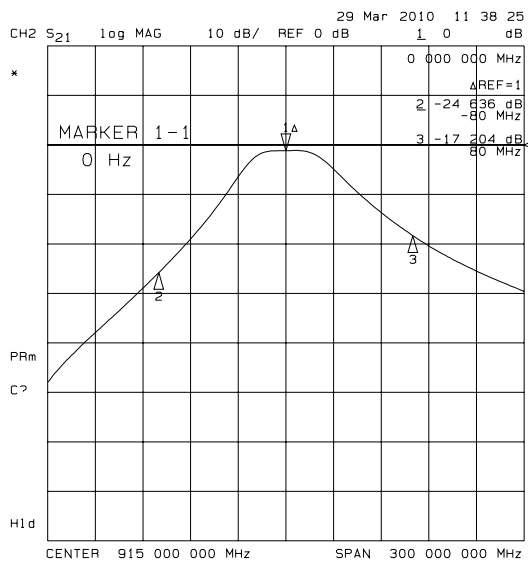

6. DEFINITIONS

	DESCRIPTION	SPECIFICATION
Center Frequency	The midpoint of through band pass filter pass band, normally expressed as the arithmetic mean of the -3dB point. Also called f_0 .	3. SPECIFICATION
Pass Band Width	The width of the pass band of a filter referenced to the minimum insertion loss point in the pass band. The pass band of a filter is stated as -1.0dB bandwidth.	
Insertion Loss	The loss of the filter, in dB, measured at center frequency relative to a through line (0 dB).	
Attenuation	Reduction of RF power through a filter measured in dB, at desired band and referenced to 0 dB. (Filter to be removed from circuit)	
Pass Band Ripple	Variations in loss in the pass band of the filter, superimposed upon the fundamental shape of the pass band.	
V.S.W.R in Pass Band	The ratio of the maximum value of a standing wave to its minimum value, related to the return loss in pass band.	